



English

Original Instructions

Installation, Operation and Maintenance Instructions

Compact EZ Strip Range

Spares & Service Contact Details

Mono UK

Spares	+44 (0)161 214 2380 (direct line 8.15 am – 5.00 pm)
E-mail	spares@mono-pumps.com
Service	+44 (0)161 214 2390 (direct line 8.15 am – 5.00 pm)
E-mail	customerservices@mono-pumps.com
Service	+44 (0)161 339 9000 (24 hrs)

Mono Australia

	Telephone	Facsimile
Melbourne	(03) 9580 5211	(03) 9580 9036
Sydney	(02) 9521 5611	(02) 9542 3649
Brisbane	(07) 3350 4582	(07) 3350 3750
Adelaide	(08) 8447 8333	(08) 8447 8373
Perth	(08) 9479 0444	(08) 9479 0400
Darwin	(08) 8984 3099	(08) 8947 0540
Tasmania	0417 345 814	(03) 6330 2051
E-mail	ozsales@mono-pumps.com	

Mono New Zealand

Spares & Service	+64 (0)9 829 0333
E-mail	info@mono-pumps.co.nz

Monoflo USA

Spares & Service	+1 713 466 7999
E-mail	inquire@monoflo.com

Monoflo South America

Spares & Service	+54 4296 8997	+54 4284 0323
E-mail	inquire@monoflo.com	

Mono China

	Telephone	Facsimile
Beijing	+86 (0) 10 6461 1115	+86 (0) 10 8486 8481
Shanghai	+86 (0) 21 5915 7168	+86 (0) 21 5915 6863
E-mail	monoshanghai@nov.com	

ATEX Warning Statements

PUMPS AND PUMP UNITS

Where a pump or pump unit is to be installed in a potentially explosive atmosphere ensure that this has been specified at the time of purchase and that the equipment has been supplied accordingly and displays an ATEX nameplate or is supplied with a certificate of conformity. If there is any doubt as to the suitability of the equipment please contact Mono Pumps Limited before commencing with installation and commissioning.

Process liquids or fluids should be kept within specified temperature limits otherwise the surface of pump or system components may become an ignition source due to temperature rises. Where the process liquid temperature is less than 90°C the maximum surface temperature will not exceed 90°C provided the pump is installed, operated and maintained in accordance with this manual. Where the process fluid temperature exceeds 90°C the maximum surface temperature will be equal to the maximum process fluid temperature.

Cavities that could allow the accumulation of explosive gases, such as under guards, should where possible, be designed out of the system. Where this is not possible they should be fully purged before any work is carried out on the pump or system.

Electrical installation and maintenance work should only be carried out by suitably qualified and competent persons and must be in accordance with relevant electrical regulations.

All electrical equipment, including control and safety devices, should be suitably rated for the environment in to which they are installed.

Where there may be a risk of an accumulation of explosive gases or dust non-sparking tools should be used for installation and maintenance.

In addition to causing permanent damage to the stator, dry running of the pump could generate a rapid rise in the temperature of the stator tube or barrel, which could become an ignition source. It is therefore essential that a dry run protection device be fitted. This must shut the pump down immediately should a dry run situation occur. Details of suitable devices are available from Mono Pumps Limited.

To minimise the risk of sparking or temperature rises due to mechanical or electrical overload the following control and safety devices should be fitted in addition to a dry run protection system. A pressure relief system whereby the pump can not generate pressures in excess of the maximum rated pressure or an over pressure device which should shut the pump down when the maximum discharge pressure is exceeded. A control system that will shut the pump down if the motor current or temperature exceed specified limits. An isolator switch that will disconnect all electrical supply to the motor and ancillary electrical equipment and be capable of being locked in the off position. All control and safety devices should be fitted, operated and maintained in accordance with the manufacturer's instructions. All valves on the system should be open when the pump is started otherwise serious mechanical overload and failure may result.

It is important that the pump rotates in the direction indicated on the nameplate. This must be checked on installation and commissioning and after any maintenance has been carried out. Failure to observe this may lead to dry running or mechanical or electrical overload.

ATEX Warning Statements

When fitting drives, couplings, belts, pulleys and guards to a pump or pump unit it is essential that these are correctly fitted, aligned and adjusted in accordance with the manufacturer's instructions. Failure to do so may result in sparking due to unintended mechanical contact or temperature rises due to mechanical or electrical overload or slipping of drive belts. Regular inspection of these parts must be carried out to ensure they are in good condition and replacement of any suspect part must be carried out immediately.

Mechanical seals should be suitably rated for the environment. The seal and any associated equipment, such as a flushing system, must be installed, operated and maintained in accordance with the manufacturer's instructions.

Where a packed gland seal is fitted this must be correctly fitted and adjusted. This type of seal relies on the process liquid to cool the shaft and packing rings so a constant drip of liquid from the gland section is required. Where this is undesirable an alternative seal type should be fitted.

Failure to operate or maintain the pump and ancillary equipment in line with the manufacturer's instructions may lead to premature and potentially dangerous failure of components. Regular inspection, and where necessary replacement, of bearings and lubrication is essential.

The pump and its components have been designed to ensure safe operation within the guidelines covered by legislation. Accordingly Mono Pumps Limited have declared the machine safe to use for the duty specified as defined by the Declaration of Incorporation or Conformity that is issued with this instruction manual.

The use of replacement parts that are not manufactured by or approved by Mono Pumps Limited may affect the safe operation of the pump and it may therefore become a safety hazard to both operators and other equipment. In these circumstances the Declaration provided will become invalid. The guarantee referenced on the Terms and Conditions of Sale will also be invalidated.

Index

SECTION 1	INSTALLATION
	START-UP PROCEDURE
	ASSEMBLY AND DISMANTLING ADVICE
SECTION 2	FAULT FINDING
SECTION 3	DRAWING REFERENCE NUMBERS
	PUMP CODING SHEET
SECTION 4	DISMANTLING AND ASSEMBLY DIAGRAMS
	EXPLODED VIEWS
SECTION 5	TORQUE TIGHTENING FIGURES

EC Declaration as defined by Machinery Directive 2006/42/EC.

The following harmonised standards are applicable: BS EN 809, BS EN ISO 12100 Parts 1 & 2

EC Declaration of Incorporation

This declaration is only valid when partly completed machinery has been supplied.

In this case, the machinery meets the requirements of the said directive and is intended for incorporation into other machinery or for assembly with other machinery in order to constitute relevant machinery as defined by the said directive including any amendments, which are valid at the time of supply.

IMPORTANT

This machinery must not be put into service until the relevant machinery into which it is to be incorporated has been declared in conformity to the said directive.

This declaration is only valid when the machinery has been installed, operated and maintained in accordance with these instructions and safety guidelines contained within as well as instructions supplied for equipment assembled with or intended for use with this equipment.

EC Declaration of Conformity

This declaration is not valid for partly completed machinery has been supplied.

In this case the machinery meets the requirements of the said directive including any amendments which are valid at the time of supply.

We further declare that, where applicable, said machinery also meets the requirements of:

The EMC Directive 2004/108/EC
The Low Voltage Directive 2006 /95/E
The Pressure Equipment Directive 97/23/EC
The Outdoor Noise Directive 2005/88/EC
The Drinking Water Directive 99/83/EC

IMPORTANT

This declaration is only valid when the machinery has been installed, operated and maintained in accordance with these instructions and safety guidelines contained within as well as instructions supplied for equipment assembled with or intended for use with this equipment.



**Mr C. Q. Griffiths - Engineering Services Manager.
for Mono Pumps Limited, Martin Street, Audenshaw,
Manchester England, M34 5JA**

Installation, Operation & Maintenance Instructions

INSTALLATION

1.1 INSTALLATION AND SAFETY RECOMMENDATIONS

In common with other items of process plant a pump must be installed correctly to ensure satisfactory and safe operation. The pump must also be maintained to a suitable standard. Following these recommendations will ensure that the safety of personnel and satisfactory operation of the pump is achieved.

1.2.1. GENERAL

When handling harmful or objectionable materials, adequate ventilation must be provided in order to disperse dangerous concentrations of vapours. It is recommended that wherever possible, Mono pumps should be installed with provision for adequate lighting, thus ensuring that effective maintenance can be carried out in satisfactory conditions. With certain product materials, a hosing down facility with adequate draining will simplify maintenance and prolong the life of pump components. Pumps operating on high temperature duties should be allowed to cool sufficiently before any maintenance is carried out.

1.2.2. SYSTEM DESIGN & INSTALLATION

At the system design stage, consideration must be given to provision of filler plugs, and the installation of non-return and/or isolating valves. Pumps cannot be reliably used as non-return valves. Pumps in parallel and those with high static discharge head must be fitted with non-return valves.

The pumps must also be protected by suitable devices against over pressure and dry running.

i. HORIZONTAL MOUNTING

All ranges excluding P Range Mono pumps are normally installed in a horizontal position with baseplates mounted on a flat surface, grouted in and bolted, thus ensuring firm fixing and a reduction in noise and vibration.

The unit should be checked after bolting down to ensure that the alignment of the pump to its prime mover is correct.

ii. VERTICAL MOUNTING

P Range Pumps Only

The P range pumps are intended for vertical installation. Care must be taken when lifting the pump into the vertical position.

Normally 'P' range pumps will be designed with a sole plate that will be bolted to the customers framework.

If the pump is to be mounted in any way other than described above, confirmation of the installation must be agreed with Mono Pumps Limited. All the pipework should be independently supported.

1.3.1 HANDLING



During installation and maintenance, attention must be paid to the safe handling of all items. Where a pump or its components weigh in excess of 20 kg (45lb) it is recommended that suitable lifting tackle should be used to ensure that personal injury or damage to components does not occur.

For safe handling of both bareshaft pumps and pump units (pump/ gearbox/motor etc.) slings should be used. The position of the slings will depend upon the specific pump/unit construction and should be carried out by personnel with the relevant experience to ensure that the pump is not damaged and injury to personnel does not occur.

If eyebolts do exist then these should only be used for lifting the individual components for which they are supplied.

1.3.2 STORAGE AND INFREQUENT OPERATION

The situation where a pump is used infrequently is also covered by the instructions in this section.

SHORT TERM STORAGE

Where a pump has to be stored for 6 months or less then the following steps are advised:-

1. Store pump inside wherever possible or if this is not feasible then provide protective covering. Do not allow moisture to collect around the pump.
2. Remove the drain plug, if fitted. Any inspection plates fitted should also be removed to ensure that the suction housing can drain and dry completely.
3. Loosen the packed gland and inject sufficient grease into the stuffing box. Tighten the gland nut hand tight. If a water flush system is to be used do not grease, a small amount of light oil is recommended for these.
4. See Manufacturers Instructions for motor/gearbox/drive instructions for storage procedures.

NOV Mono®

One Company, Unlimited Solutions

Installation, Operation & Maintenance Instructions

LONG TERM STORAGE

If the pump is to be kept in storage for more than six months then in addition to the above the following procedures should be carried out regularly (every 2 - 3 weeks if possible):

1. If practicable rotate the pump at least three quarters of one revolution to avoid the rotor setting in the stator.
2. Note, however, that the pump is not to be rotated for more than two revolutions each time because damage could be caused to the rotor/ stator elements.

IMMEDIATELY PRIOR TO INSTALLATION AND STARTING



Before installing the pump please ensure that all plugs and inspection plates are replaced and that excess grease/oil is removed from the stuffing box.

1.4 ELECTRICAL



Electrical connection should only be made using equipment suitable for both rating and environment. Where any doubts exist regarding the suitability of equipment, Mono Pumps Limited, should be consulted before proceeding. Normally the Mono pump should be installed with starting equipment arranged to give direct on line starting.

Earthing points will be provided on electric drives (if supplied) and it is essential that these are correctly connected. When the motor is being wired and checked for rotation, the start/stop sequence must be instantaneous to prevent dry running (see 2) or pressurising upstream equipment. (Check direction arrow on pump nameplate). The electrical installation should include appropriate isolating equipment to ensure that the pump unit is safe to work on.

1.5 PRESSURE RELIEF VALVES AND NON-RETURN VALVES

1. It is recommended that a suitable safety device is installed on the discharge side of the pump to prevent over-pressurisation of the system.
2. It is also recommended that a non-return valve is installed on the discharge side of the pump to prevent reverse flow through the system.

When both are installed it is advised that the relief valve is positioned closer to the pump than the non-return valve.

IMPORTANT



The pump must never run against a closed inlet or outlet valve, as this could result in mechanical failure.

1.6 GENERAL SAFETY



GREAT CARE MUST BE TAKEN TO PROTECT ALL ELECTRICAL EQUIPMENT FROM SPLASHING WHEN HOSING DOWN. WHERE MONO PUMPS LIMITED HAVE SUPPLIED A BARESHAFT PUMP THE ONUS IS ON THE USER TO FIT ADEQUATE GUARDS IN COMPLIANCE WITH THE REQUIREMENTS OF THE RELEVANT REGULATIONS.

All nuts and bolts, securing flanges and base mounting fixtures must be checked for tightness before operation. To eliminate vibration, the pump must be correctly aligned with the drive unit, and all guards must be securely fixed in position. When commissioning the plant, all joints in the system must be checked thoroughly for leakage.

If, when starting, the pump does not appear to operate correctly (see 2), the plant must be shut down immediately and the cause of the malfunction established before operations are recommenced. It is recommended that depending upon plant system operation, either a combined vacuum and pressure gauge, or a vacuum gauge only be fitted to the pump inlet port, and a pressure gauge fitted to the outlet port, these will then continuously monitor the pump operating conditions. May contain substances from the ECHA SVHC Candidates List (REACH - Regulation (EC) No. 1907/2006)

1.7 DUTY CONDITIONS

Pumps should only be installed on duties for which Mono Pumps Limited have specified the materials of construction, flow rates, pressure, temperature, speed etc. Where dangerous materials are to be pumped, consideration must be given to the safe discharge from relief valves, gland drains etc.

IF THE DUTY SHOULD BE CHANGED, MONO PUMPS LIMITED SHOULD BE CONTACTED AND THEIR RECOMMENDATIONS SOUGHT IN THE INTEREST OF APPLICATION, SAFETY OF PLANT, EFFICIENCY AND PUMP LIFE.

NOV Mono®

One Company, Unlimited Solutions

Installation, Operation & Maintenance Instructions

2. START-UP PROCEDURE

Pumps must be filled with liquid before starting. The initial filling is not for priming purposes, but to provide the necessary lubrication of the stator until the pump primes itself. When the pump is stopped, sufficient liquid will normally be trapped in the rotor/stator assembly to provide lubrication upon re-starting.

If, however, the pump has been left standing for an appreciable time, moved to a new location, or has been dismantled and re-assembled, it must be refilled with liquid and given a few turns before starting. The pump is normally somewhat stiff to turn by hand owing to the close rotor/stator fit. However, this stiffness disappears when the pump is running normally against pressure.

2.1 DRY RUNNING



NEVER RUN THE PUMP IN A DRY CONDITION EVEN FOR A FEW REVOLUTIONS OR THE STATOR WILL BE DAMAGED IMMEDIATELY. CONTINUAL DRY RUNNING COULD PRODUCE SOME HARMFUL OR DAMAGING EFFECTS.

2.2 PUMP ROTATION DETAILS

<u>PUMP RANGE</u>	<u>BI-DIRECTIONAL</u>	<u>COMMENT</u>
E	Yes	†
Monobloc B	Yes	†
Compact (inc EZ strip)	Yes	†
Merlin Industrial	Yes	†
S, SL	Yes	†
LF	Yes	†
W	No	**
Merlin Widethroat	No	**
MM ML	No	*
MS	No	**
G	No	*
CB/SB	No	*
Placer	No	**
Grout Injection	No	**
P	No	*
CP0011	No	**
CP0025,CP0800,CP1600	No	*

* Clockwise when viewed from drive end.

** Anti-clockwise when viewed from drive end.

† Anti-clockwise gives inlet at drive end.

DIRECTIONS OF ROTATION



BEFORE THE DIRECTION OF ROTATION IS CHANGED, MONO PUMPS LIMITED MUST BE CONSULTED SO THAT THE SUITABILITY OF THE PUMP CAN BE CONFIRMED WHEN OPERATING ON THE NEW DUTY.

2.3.1. GLAND PACKING

Where a pump is supplied fitted with gland packing (manufactured from a non-asbestos material), the gland will require adjustment during the initial running in period. Newly packed glands must be allowed to run-in with only finger tight compression on the gland follower nuts. This should continue for about 3 days. The gland follower should be gradually tightened over the next week to achieve a leakage rate as shown in the table below. Gland followers should be adjusted at regular intervals to maintain the recommended leakage flow rate. Under normal working conditions a slight drip from the gland under pressure assists in cooling and lubricating the packing. **A correctly adjusted gland will always have small leakage of fluid.**

Typical Leakage Rates from Packed Glands

<u>Up to 50mm shaft diameter</u>	<u>2 drops per minute</u>
<u>50 ... 75mm shaft diameter</u>	<u>3 drops per minute</u>
<u>75 ... 100mm shaft diameter</u>	<u>4 drops per minute</u>
<u>100 ... 125mm shaft diameter</u>	<u>5 drops per minute</u>
<u>125 ... 160mm shaft diameter</u>	<u>6 drops per minute</u>

A gland drip is, however, undesirable when handling corrosive, degreasing, or abrasive materials. Under these conditions the gland must be tightened the minimum amount whilst the pump is running to ensure satisfactory sealing when under pressure, or to stop entry of air when under suction conditions.

The gland leakage of toxic, corrosive or hazardous liquids can cause problems of compatibility with the pumps materials of construction.

Provision of a gland drain should be considered, especially for the leakage of hazardous products.



CARE IS REQUIRED WHEN ADJUSTING THE GLAND WHILST PUMP IS RUNNING.

2.3.2 MECHANICAL SEALS - ALL PUMPS

When a mechanical seal is fitted to the pump it may be necessary to provide a barrier fluid to some part of the seal. This should be provided in line with the seal manufacturers instructions.

2.4. GUARDS



In the interests of safety, and in accordance with the U.K. Health and Safety at Work Act 1974, all guards must be replaced after necessary adjustments have been made to the pump.

Installation, Operation & Maintenance Instructions

2.5 WARNING/CONTROL DEVICE

Prior to operating the pump, if any warning or control devices are fitted these must be set in accordance with their specific instructions.

2.6 PUMP OPERATING TEMPERATURE

The range of temperatures the pump surfaces will develop is dependent upon factors such as product temperature and ambient temperature of the installation. There may be instances where the external pump surface can exceed 50°C.

In these instances, personnel must be made aware of this and suitable warnings/guarding used.

2.7 NOISE LEVELS

1. The sound pressure level should not exceed 85dB at one metre distance from the pump.
2. This is based on a typical installation and does not necessarily include noise from other sources or any contribution from building reverberation or installation pipework
3. It is recommended the actual pump unit noise levels are ascertained once the unit is installed and running at duty conditions

2.8 LUBRICATION

Pumps fitted with bearings should be inspected periodically to see if grease replenishment is necessary, and if so, grease should be added until the chambers at the ends of the bearing spacer are approximately one third full.

Periodic bearing inspection is necessary to maintain optimum bearing performance. The most expedient time to inspect is during periods of regular scheduled equipment downtime - for routine maintenance or for any other reason.

Under tropical or other arduous conditions, however, a more frequent examination may be necessary. It is therefore advisable to establish a correct maintenance schedule or periodic inspection.

BP LC2 / Mobilgrease XHP 222 or their equivalent must be used for replenishment.

2.9 PUMP UNITS

Where a pump unit is dismantled and re-assembled, consideration must be given to ensure that where appropriate the following steps are covered.

1. Correct alignment of pump/gearbox
2. Use of appropriate couplings & bushes
3. Use of appropriate belts & pulleys correctly tensioned.

2.10 CLEANING PRIOR TO OPERATION

i. Non Food Use

During the commissioning of a new pump or recommissioning of an overhauled pump, it is advisable to clean the pump prior to the initial operation of the pump in the process.

ii. Food Use

When a pump has been supplied for a food application, it is important to ensure that the pump is clean prior to initial operation of the pump.

Therefore, it is important that a clean-in-place treatment is executed on the pump at the following times:-

1. When the pump is first commissioned for use.
2. When any spare components are fitted into the wetted area of the pump.

A recommended CIP procedure is as follows:

This procedure should not be used on the CP Pump Range. Please consult our application engineers for a suitable procedure.

Caustic Wash

LQ94 ex Lever Diversey or equivalent
2% concentration

Acid Wash

P3 Horolith 617 ex Henkel
Ecolab or equivalent 1% concentration

Procedure

1. Caustic wash @ 75°C for 20 mins
2. Water rinse @ 80°C for 20 mins

Installation, Operation & Maintenance Instructions

3. Acid wash @ 50°C for 20 mins
4. Water rinse @ 80°C for 20 mins

- CIP flow rates (hence pump speeds) should be maximised to achieve highest level of cleanability.

A C.I.P. liquid velocity of 1.5 to 2.0 m/s is required for removal of solids and soiling.

Pumps fitted with CIP by pass ports will permit higher flow rates without the need to increase pump speed.

- The use of neat active caustic and acid chemicals is not recommended. Proprietary cleaning agents should be used in line with manufacturers instructions.
- All seals and gaskets should be replaced with new if disturbed during maintenance.
- Pump internals should be regularly inspected to ensure hygienic integrity is maintained, especially with respect to elastomeric components and seals, and replaced if necessary.

The four stages constitute one cycle and we recommend that this cycle is used to clean the pump before use on food.

Once the pump has been commissioned, the cleaning process will depend upon the application. The user must therefore ensure that their cleaning procedures are suitable for the duty for which the pump has been purchased.

2.11 WIDETHROAT PUMPS

Specific pumps may have auger feed screws, with or without a bridge breaker system to feed the pumping element. If the pump installation requires that these cannot be enclosed, care must be taken to ensure personnel cannot gain access whilst the pump is operating. If this is not possible an emergency stop device must be fitted nearby.

2.12 EXPLOSIVE PRODUCTS/ HAZARDOUS ATMOSPHERES

In certain instances the product being pumped may well be of a hazardous nature.

In these installations consideration must be given to provide suitable protection and appropriate warnings to safeguard personnel and plant.

2.13 ACCESS PORTS



Where access ports are fitted then the following steps must be followed prior to removal:

1. Pump must be shut down and the electrical supply isolated.
2. Protective clothing should be worn, especially if the pumped product is obnoxious.
3. Remove access plate with care utilising where possible drip trays to collect product leakage.

Access ports are included to assist in removing blockages and to allow a visual check on the components within the suction chamber.

It is not to be considered as an additional method in dismantling the pump.

Re-assembly of the plate should be completed using new gaskets prior to the pump being switched on.

2.14 ADJUSTABLE STATORS

If adjustable stators are fitted then the following steps must be followed for adjusting the clamping devices.

The adjustable stator assembly is designed to give an even compression around the stator circumference. It is designed to be used when pump performance reduces through wear to an unacceptable level, to restore the required flow rate.

The stator compression is increased using the following steps:-

1. Release the six locking screws half a turn.
2. Tighten the eight clamp screws until adjustment allowed by releasing the lock screws has been taken up.
3. Repeat steps 1 and 2 until the pump performance has been restored to its former level.

NOTE

It is imperative that when adjusting the stator that only sufficient pressure is placed on the stator to enable the capacity of the pump to be reinstated.

Over tightening of the stator could easily result in damage to the driver by overload and so extreme care must be taken when carrying out these adjustments.

 **Mono**[®]

One Company, Unlimited Solutions

Installation, Operation & Maintenance Instructions

It is therefore advisable to make the adjustment while the pump is running and power readings can be monitored.

REMOVAL OF ADJUSTABLE STATOR

The procedure for removal of an adjustable stator is the same as that of a standard one, except it is necessary to remove the clamp plates before the stator can be twisted off the rotor.

This can be done by undoing the clamp screws; then releasing the clamp plate by using the locking screws as jacking screws to remove the clamp plates.

Re-assembly will be done using the reverse procedure.

2.15 MAINTENANCE OF WEARING COMPONENTS

2.15.1 ROTOR AND STATOR

The wear rate on these components is dependent on many factors, such as product abrasivity, speed, pressure etc.

When pump performance has reduced to an unacceptable level one or possibly both items will need replacing.

2.15.2 DRIVE SHAFT - PACKED GLAND

The wear rate of the gland area is dependent on many factors such as product abrasivity and speed. Regular gland maintenance will maximise the life of the shaft. Replacement of both the gland packing and shaft will be necessary when shaft sealing becomes difficult to achieve.

2.15.3 COUPLING ROD JOINTS

Regular maintenance and lubrication will maximise life of the joints.

Replacement of one or both joint assemblies and possibly the coupling rod may be necessary when wear is apparent.

It is essential to replace all the joint items with genuine Mono parts to ensure maximum life.

2.15.4 FLEXISHAFT DRIVE PUMPS

With this design there are no wearing items to replace in the drive train, however, if during routine inspection the shaft is visibly damaged / distorted or the protective coating is damaged, then this item should be replaced to avoid unexpected breakdowns.

2.16 MECHANICAL SPEED VARIATORS

Refer to the manufacturers instructions.

These machines require regular maintenance, which typically includes weekly adjustment through the full speed range.

3.0 ASSEMBLY AND DISMANTLING

Section 4 contains the steps to dismantle and re-assemble the pump. All fastenings must be tightened securely and when identified the appropriate torque figures should be used.

3.1 USE OF ITEMS NOT APPROVED OR MANUFACTURED BY MONO PUMPS LIMITED

The pump and its components have been designed to ensure that the pump will operate safely within the guidelines covered by the legislation.

As a consequence Mono Pumps Limited have declared the machine safe to use for the duty specified as defined by the Declaration of Incorporation or Conformity that is issued with this Instruction Manual.

The use of replacement items that are not approved by or manufactured by Mono Pumps Limited may affect the safe operation of the pump and it may therefore become a safety hazard to both operators and other equipment. In these instances the Declaration provided will therefore become invalid. The guarantee referenced in the Terms and Conditions of Sale will also be invalidated if replacement items are used that are not approved or manufactured by Mono Pumps Limited.



DISPOSAL OF WORN COMPONENTS

When replacing wearing parts, please ensure disposal of used parts is carried out in compliance with local environmental legislation. Particular care should be taken when disposing of lubricants.

Installation, Operation & Maintenance Instructions

3.2 RECOMMENDED LIFTING POINTS

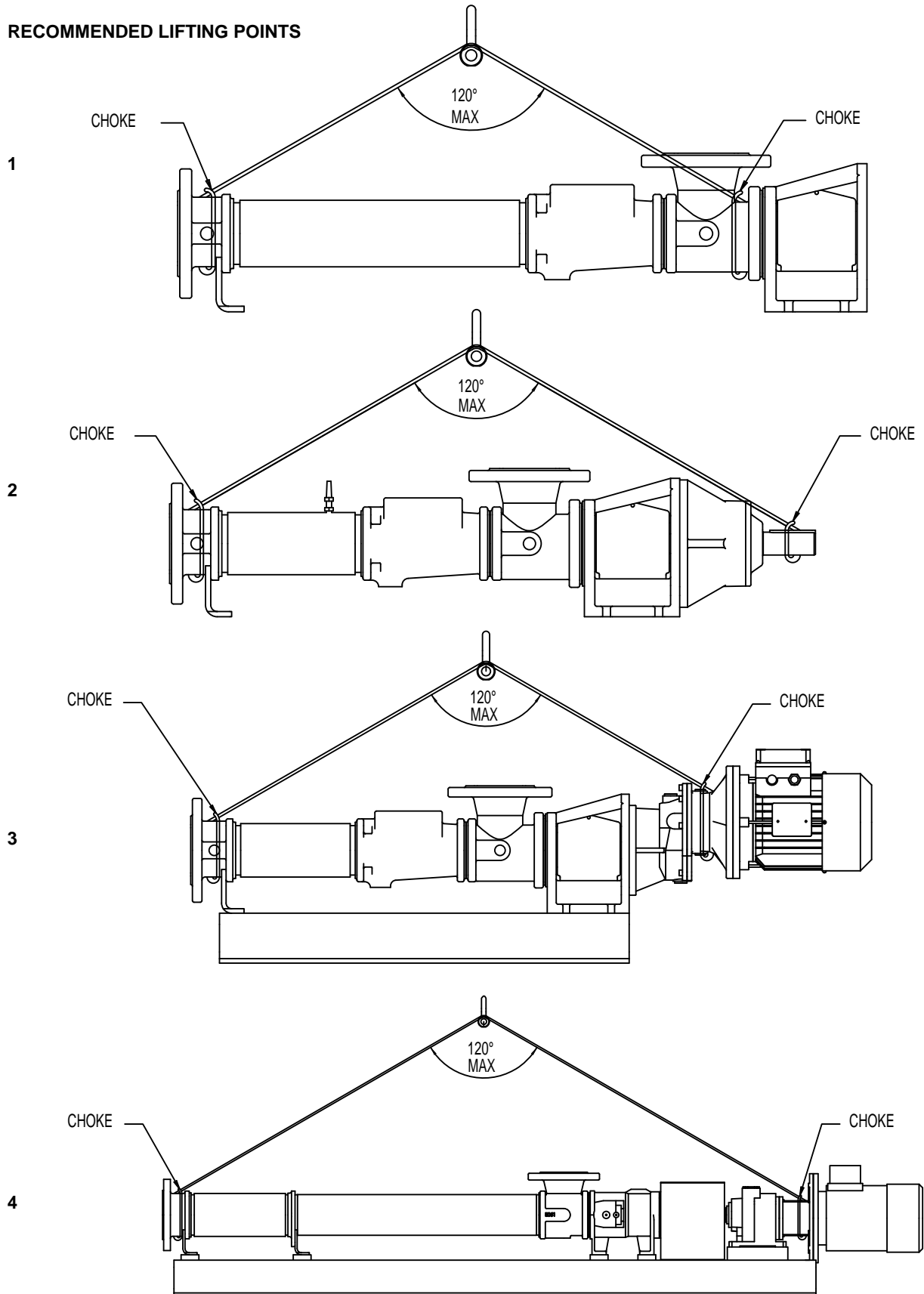

Installation, Operation & Maintenance Instructions

3.3 PUMP AND WEAR PARTS WEIGHTS.

NOTE: Weights are for guidance purpose only. Please refer to the documentation issued with your pump or spares.

EZ Strip

Model	Weight (kg)				
	Pump	Stator	Rotor	Coupling Rod/Joint	Shaft
Z14A	34	3.5	2.6	1.2	1.7
Z14B	46	7.1	4.5	1.2	1.7
Z14K	42	7.1	4.5	1.2	1.7
Z15A	50	6.3	4.9	1.2	1.7
Z15B	70	12.4	9.1	2.4	3.1
Z15K	57	12.3	8.8	1.2	1.7
Z16A	77	11.0	8.4	2.4	3.1
Z16B	102	21.5	15.4	4.9	4.4
Z16K	94	5.0	15.3	2.4	3.1
Z17A	107	17.4	13.3	4.9	4.3
Z17B	150	34.3	24.5	4.6	4.3
Z17K	148	34.3	24.5	4.6	4.3
Z18A	113	23.1	17.9	6.2	4.3
Z18B	170	24.6	33.7	12.3	8.7
Z18K	172	45.0	33.0	6.2	4.3
Z19A	175	41.7	25.8	12.3	8.7
Z19B	286	65.9	47.6	12.3	8.7
Z19K	270	67.2	47.6	12.3	8.7
Z1AA	215	37.4	38.8	12.3	8.7
Z1AK	301	74.4	71.4	12.3	8.7

Diagnostic Chart

SYMPTOMS	POSSIBLE CAUSES
1. NO DISCHARGE 2. LOSS OF CAPACITY 3. IRREGULAR DISCHARGE 4. PRIMING LOST AFTER START 5. PUMP STALLS AT START UP 6. PUMP OVERHEATS 7. MOTOR OVERHEATS 8. EXCESSIVE POWER ABSORBED BY PUMP 9. NOISE AND VIBRATION 10. PUMP ELEMENT WEAR 11. EXCESSIVE GLAND OR SEAL WEAR 12. GLAND LEAKAGE 13. SEIZURE	1. 2. 3. 7. 26. 28. 29. 3. 4. 5. 6. 7. 8. 9. 10. 22. 13. 16. 17. 21. 22. 23. 29 3. 4. 5. 6. 7. 8. 13. 15. 29. 3. 4. 5. 6. 7. 8. 13. 15 8. 11. 24. 8. 9. 11. 12. 18. 20 8. 11. 12. 15. 18. 20. 8. 11. 12. 15. 18. 20 3. 4. 5. 6. 7. 8. 9. 11. 13. 15. 18. 19. 20. 22. 23. 27. 31 9. 11. 12. 14. 25. 30. 13. 14. 9. 11. 12. 20.
LIST OF CAUSES	REMEDIAL ACTIONS
1. INCORRECT DIRECTION OF ROTATION 2. PUMP UNPRIMED 3. INSUFFICIENT N.P.S.H. AVAILABLE 4. PRODUCT VAPORISING IN SUPPLY LINE 5. AIR ENTERING SUPPLY LINE 6. INSUFFICIENT HEAD ABOVE SUPPLY VESSEL OUTLET 7. FOOTVALVE/STRAINER OBSTRUCTED OR BLOCKED 8. PRODUCT VISCOSITY ABOVE RATED FIGURE 9. PRODUCT TEMP. ABOVE RATED FIGURE 10. PRODUCT VISCOSITY BELOW RATED FIGURE 11. DELIVERY PRESSURE ABOVE RATED FIGURE 12. GLAND OVERTIGHT 13. GLAND UNDERTIGHT 14. GLAND FLUSHING INADEQUATE 15. PUMP SPEED ABOVE RATED FIGURE 16. PUMP SPEED BELOW RATED FIGURE 17. BELT DRIVE SLIPPING 18. COUPLING MISALIGNED 19. INSECURE PUMP/DRIVE MOUNTING 20. SHAFT BEARING WEAR/FAILURE 21. WORN PUMP ELEMENT 22. RELIEF VALVE CHATTER 23. R.V. INCORRECTLY SET 24. LOW VOLTAGE 25. PRODUCT ENTERING PACKING AREA 26. DRIVE TRAIN BREAKAGE 27. NEGATIVE OR VERY LOW DELIVERY HEAD 28. DISCHARGE BLOCKED/VALVE CLOSED 29. STATOR TURNING 30. STUFFING BOX 'EATS' PACKING 31. VEE BELTS	1. REVERSE MOTOR 2. BLEED SYSTEM OF AIR/GAS 3. INCREASE SUCTION HEAD OR REDUCE SPEED/TEMP. 4. INCREASE N.P.S.H. AVAILABLE (SEE 3 ABOVE) 5. CHECK PIPE JOINTS/GLAND ADJUSTMENT 6. RAISE VESSEL/INCREASE PIPE SIZE 7. CLEAN OUT SUCTION LINE/VALVES 8. DECREASE PUMP SPEED/INCREASE TEMP. 9. COOL THE PRODUCT 10. INCREASE PUMP SPEED/REDUCE TEMP. 11. CHECK FOR BLOCKAGES IN DELIVERY LINE 12. ADJUST GLAND SEE O&M INSTRUCTIONS 13. ADJUST GLAND SEE O&M INSTRUCTIONS 14. CHECK FLUID FLOWS FREELY INTO GLAND 15. DECREASE PUMP SPEED 16. INCREASE PUMP SPEED 17. RE-TENSION BELTS 18. CHECK AND ADJUST ALIGNMENT 19. CHECK AND TIGHTEN ALL PUMP MOUNTINGS 20. REPLACE BEARINGS 21. FIT NEW PARTS 22. CHECK CONDITION OF VALVE/RENEW 23. RE-ADJUST SPRING COMPRESSION 24. CHECK VOLTAGE/WIRING SIZES 25. CHECK PACKING CONDITION AND TYPE 26. CHECK AND REPLACE BROKEN COMPONENTS 27. CLOSE DELIVERY VALVE SLIGHTLY 28. REVERSE PUMP/RELIEVE PRESSURE/CLEAR BLOCKAGES 29. REPLACE WORN PARTS/TIGHTEN UP STATOR BOLTS 30. CHECK FOR WORN SHAFT AND REPLACE 31. CHECK AND ADJUST TENSION OR REPLACE

Drawing Reference Numbers

Z14A & ABOVE EXCLUDING Z18B

<u>DRG. REF</u>	<u>DESCRIPTION</u>
01A	BODY STD C.I.
06A	NP E RANGE SOG PACK SIZE=100
06B	NP E RANGE DOG PACK SIZE=100
10A	M/SEAL
15A	THROWER GUARD
20B	GASKET GLAND
20C	SLEEVE GASKET
20D	SUC CHAM GASKETS
22A	STATOR MTM NITRILE RUBBER
23A	SUCT CHAM C.I.
23C	SUC CHAM EXT FLANGE
23D	SUC CHAM EXT PIECE
23E	SUC CHAM HALF
24A	END COVER C.I.
25A	ROTOR (ST STL H.C.P.)
26B	SPLIT COUPLING
26C	SPLIT COUPLING
26D	SLEEVE HALVES ASSEMBLY
28A	SEALING COVER
28B	SEALING COVER
29A	COUPLING ROD PIN
29B	COUPLING ROD PIN
29C	SHAFT PIN SS
32A	316SS DRIVESHAFT
42A	THROWER
62A	SUPPORT FOOT
65A	M/SEAL CARRIER
66A	ABUTMENT RING ST STL
75A	SLEEVE (ROTOR SHAFT)
75B	SLEEVE (ROTOR SHAFT)
95A	TIE ROD

<u>DRG. REF</u>	<u>DESCRIPTION</u>
P104	STL HEX HD BOLT
P105	STL HEX NUT
P106	STL BRIGHT WASHER
P107	SNGL COIL SPR WASHER
P109	STL HEX NUT
P201	CARBON STL TAPER PLUG
P202	CARBON STL TAPER PLUG
P301	SOC CAPSCREW
P401	TORL SEAL RING BK NITR
P402	TORL SEAL RING BK NITR
P403	SPIRAL RET RING SS SHAFT
P404	SPIRAL RET RING SS SHAFT
P405	TIE SEALING COVER
P406	TIE SEALING COVER
P502	MAL IRON TAPER PLUG
P503	STL HEX NUT
P504	STL BRIGHT WASHER
P505	SNGL COIL SPR WASHER
P506	STL HEX NUT
P507	STL BRIGHT WASHER
P508	SNGL COIL SPR WASHER
P510	TORL SEAL RING BK NITR
P519	MAL IRON TAPER PLUG
P520	STL STUD (1-1/2D)
P521	STL HEX NUT
P522	STL BRIGHT WASHER
P523	SNGL COIL SPR WASHER
P527	STL HEX HD BOLT
P528	SNGL COIL SPR WASHER
P529	STL BRIGHT WASHER
P530	STL HEX NUT
P531	STL HEX HD BOLT
P532	SNGL COIL SPR WASHER
P533	STL BRIGHT WASHER
P534	STL HEX NUT
P540	SOC CAPSCREW
P541	STL HEX NUT
P601	STL HEX HD BOLT
P602	SNGL COIL SPR WASHER
P603	STL BRIGHT WASHER
P604	STL HEX NUT

IMPORTANT NOTE

THE DRAWING REFERENCES SHOWN GIVE THE DESCRIPTION OF ALL THE PARTS DETAILED ON THE SECTIONAL DRAWINGS IN THIS SECTION OF THE BOOK. THEREFORE SOME OF THE REFERENCES MAY NOT BE SHOWN ON ANY ONE.

Drawing Reference Numbers

Z18B

<u>DRG. REF.</u>	<u>DESCRIPTION</u>
01A	BODY STD C.I.
01B	BODY ADAPTOR C.I.
06A	NP E RANGE SOG PACK SIZE
06B	NP E RANGE DOG PACK SIZE
10A	M/SEAL
15A	THROWER GUARD
20A	GASKET GLAND
20B	GASKET GLAND
20C	SLEEVE GASKET
20D	SUC CHAM GASKET
22A	STATOR MTM NITRILE RUBBER
23A	SUCT CHAM C.I.
23C	SUC CHAM EXT FLANGE
23D	SUC CHAM EXT PIECE
23E	SUC CHAM HALF
24A	END COVER C.I.
25A	ROTOR (ST STL H.C.P.)
26B	SPLIT COUPLING ROD
26C	SPLIT COUPLING ROD
26D	SLEEVE HALVES ASSEMBLY
28A	SEALING COVER
28B	SEALING COVER
29A	COUPLING ROD PIN
29B	COUPLING ROD PIN
29C	SHAFT PIN SS
32A	316SS DRIVESHAFT
42A	THROWER
62A	SUPPORT FOOT
65A	M/SEAL CARRIER
66A	ABUTMENT RING ST STL
75A	SLEEVE (ROTOR SHAFT)
75B	SLEEVE (ROTOR SHAFT)
95A	TIE ROD

<u>DRG. REF.</u>	<u>DESCRIPTION</u>
P104	STL HEX HD BOLT
P105	STL HEX NUT
P106	STL BRIGHT WASHER
P107	SNGL COIL SPR WASHER
P109	STL HEX NUT
P201	CARBON STL TAPER PLUG
P202	CARBON STL TAPER PLUG
P301	SOC CAPSCREW
P401	TORL SEAL RING BK NITR
P402	TORL SEAL RING BK NITR
P403	SPIRAL RET RING SS
P404	SPIRAL RET RING SS
P405	TIE SEALING COVER
P406	TIE SEALING COVER
P501	MAL IRON TAPER PLUG
P502	MAL IRON TAPER PLUG
P503	STL HEX NUT
P504	STL BRIGHT WASHER
P505	SNGL COIL SPR WASHER
P506	STL HEX NUT
P507	STL BRIGHT WASHER
P508	SNGL COIL SPR WASHER
P509	TORL SEAL RING BK NITR
P510	TORL SEAL RING BK NITR
P511	STL STUD (1.5D)
P512	SNGL COIL SPR WASHER
P513	STL BRIGHT WASHER
P514	STL HEX NUT
P519	MAL IRON TAPER PLUG
P523	STL STUD (1.5D)
P524	SNGL COIL SPR WASHER
P525	STL BRIGHT WASHER
P526	STL HEX NUT
P527	STL STUD (1.5D)
P540	SOC CAPSCREW
P541	STL HEX NUT
P601	STL HEX HD BOLT
P602	SNGL COIL SPR WASHER
P603	STL BRIGHT WASHER
P604	STL HEX NUT

IMPORTANT NOTE

THE DRAWING REFERENCES SHOWN GIVE THE DESCRIPTION OF ALL THE PARTS DETAILED ON THE SECTIONAL DRAWINGS IN THIS SECTION OF THE BOOK. THEREFORE SOME OF THE REFERENCES MAY NOT BE SHOWN ON ANY ONE.

Pump Coding

Range	Monobloc Compact EZ Strip	Z																						
Design Mk No	Monobloc		1																					
Size	22m³/h @ 1000 rpm						4																	
	37m³/h @ 800 rpm						5																	
	57m³/h @ 700 rpm						6																	
	79m³/h @ 600 rpm						7																	
	97m³/h @ 500 rpm						8																	
	125m³/h @ 450 rpm						9																	
	165m³/h @ 400rpm						A																	
Stages	Single stage											A												
	Two stage											B												
	Single stage - extended pitch											K												
Casing Material	Cast Iron												C											
	Stainless Steel												S											
Rotating Parts 1	Code 1																			1				
	Code 5																			5				
	Code 8																			8				
Rotor Mk No	Mk 0 (Oversized)																			0				
	Mk1 (Standard)																			1				
	Mk3 (Temperature)																			3				
	Mk5 (Temperature)																			5				
Stator Material	RA, RR etc.																			R				
Seal Type	Mechanical Seal																				M			
	Packed Gland																				P			
Build Option	Refer to product manual section 2 & 3, drive selections																				A			
																					B			
																						H		
/																					/			
Variation	For special requirements contact Mono Pumps Ltd																				A	1	2	3

Example

Z 1 4 A C 8 1 R M A

EZ Strip Range
Design Mk 1
Size 04
Single Stage
Cast Iron
Code 8 Rot Parts
Mk 1 Rotor
Nitrile Stator
Mechanical Seal
Build Option A

Note: Z1AB is not currently available

Note: Refer to Pre Selection Table for availability of pump models.

1 : For other material options please contact Mono Pumps Limited.

Dismantling & Assembly Diagrams

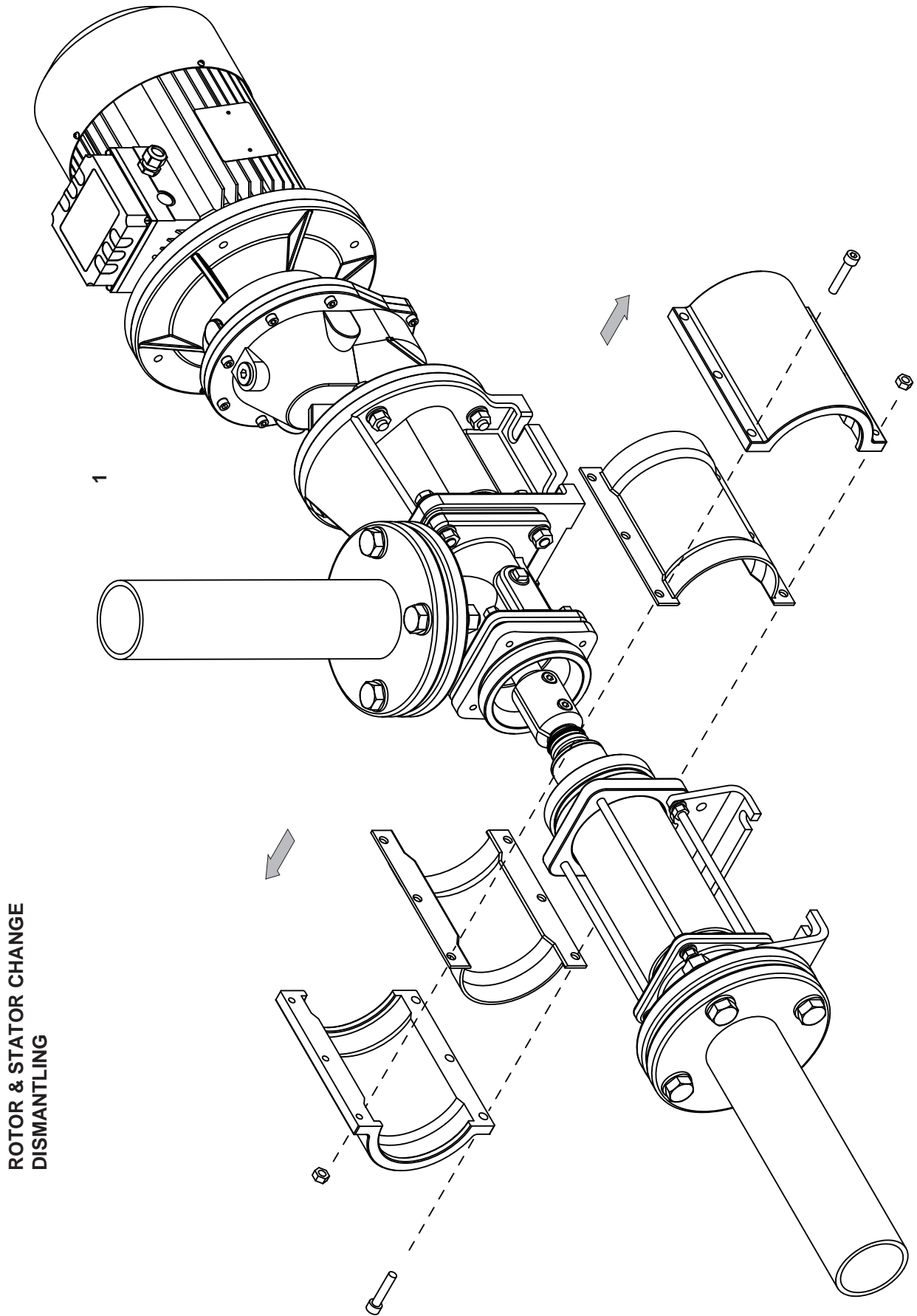

ROTOR & STATOR CHANGE
DISMANTLING

Dismantling & Assembly Diagrams

ROTOR & STATOR CHANGE
DISMANTLING

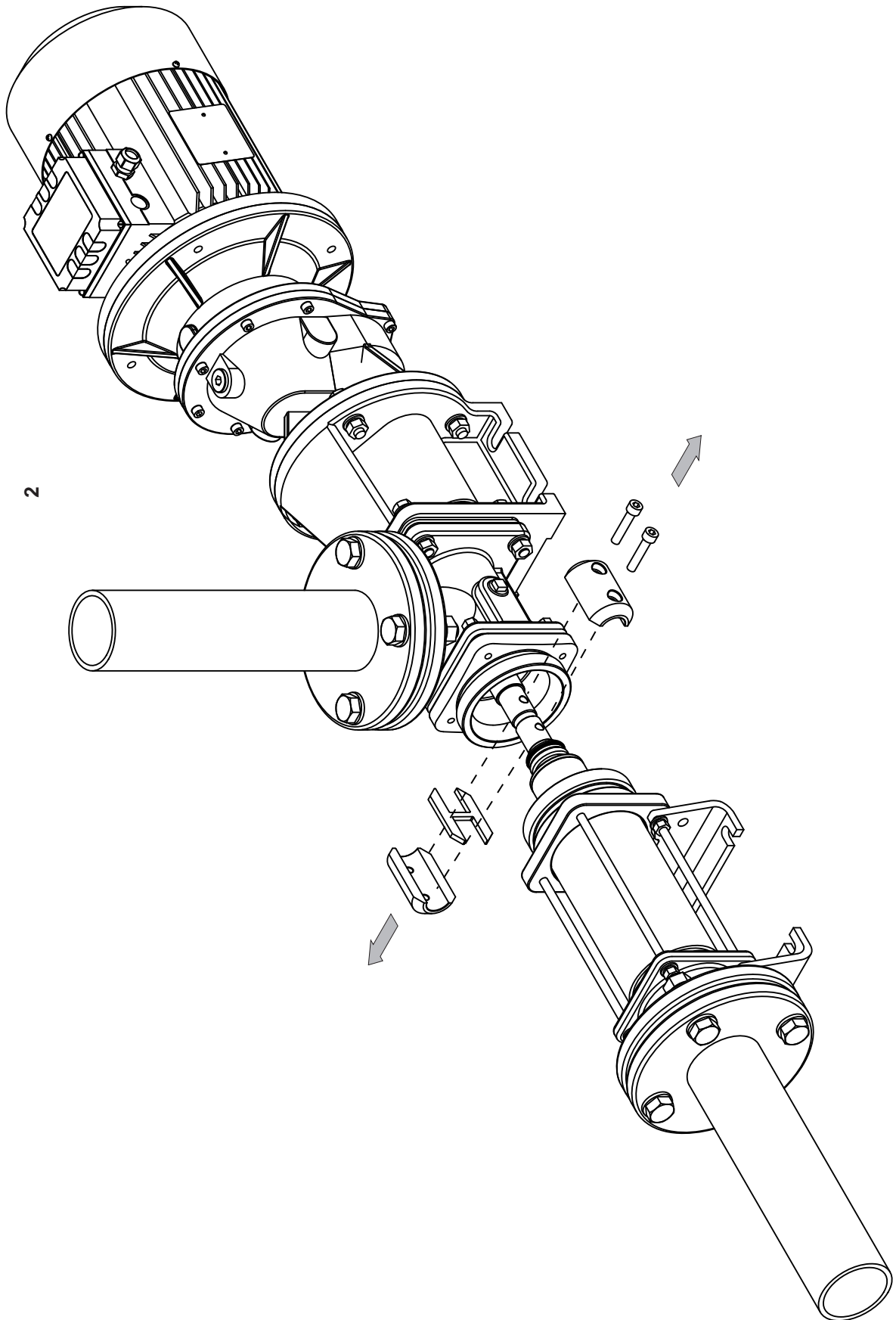

Dismantling & Assembly Diagrams

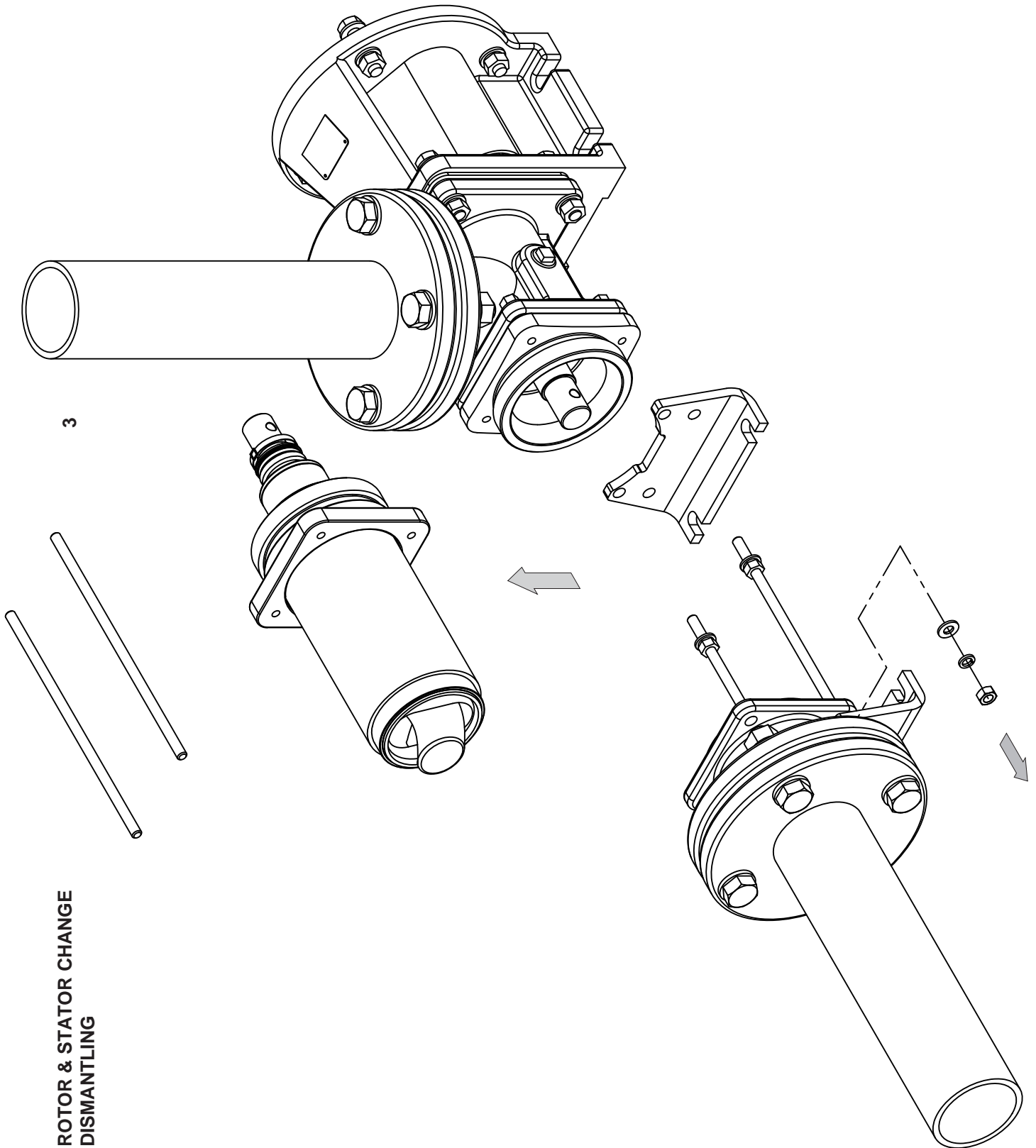

ROTOR & STATOR CHANGE
DISMANTLING

Dismantling & Assembly Diagrams

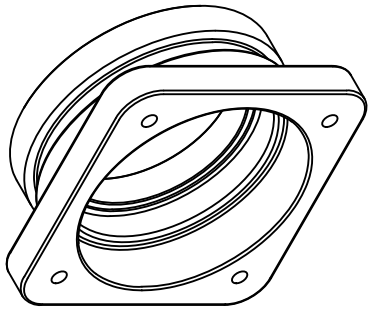

4

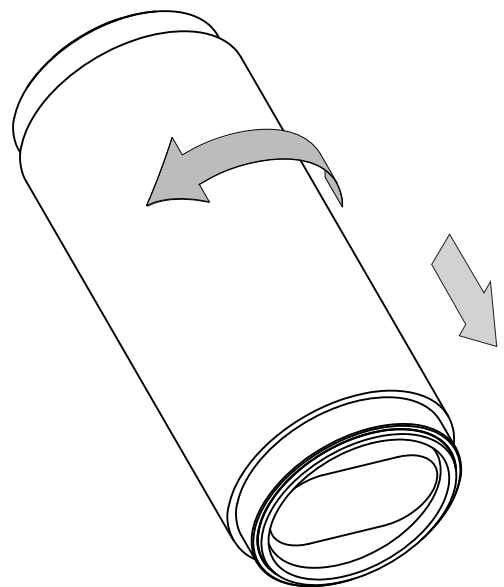
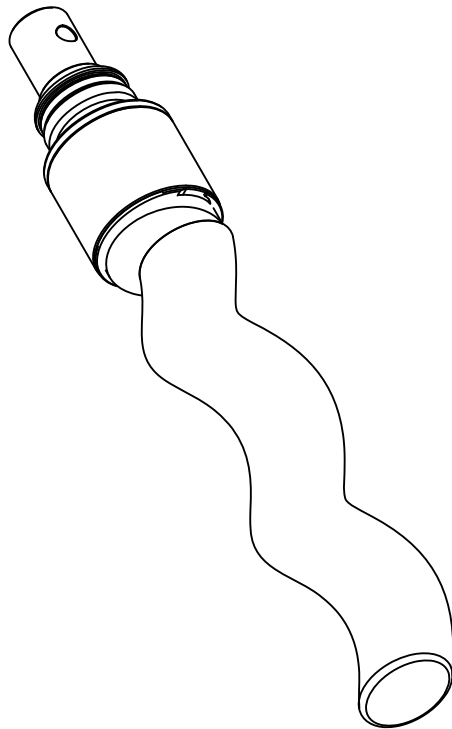

ROTOR & STATOR CHANGE
DISMANTLING

Dismantling & Assembly Diagrams

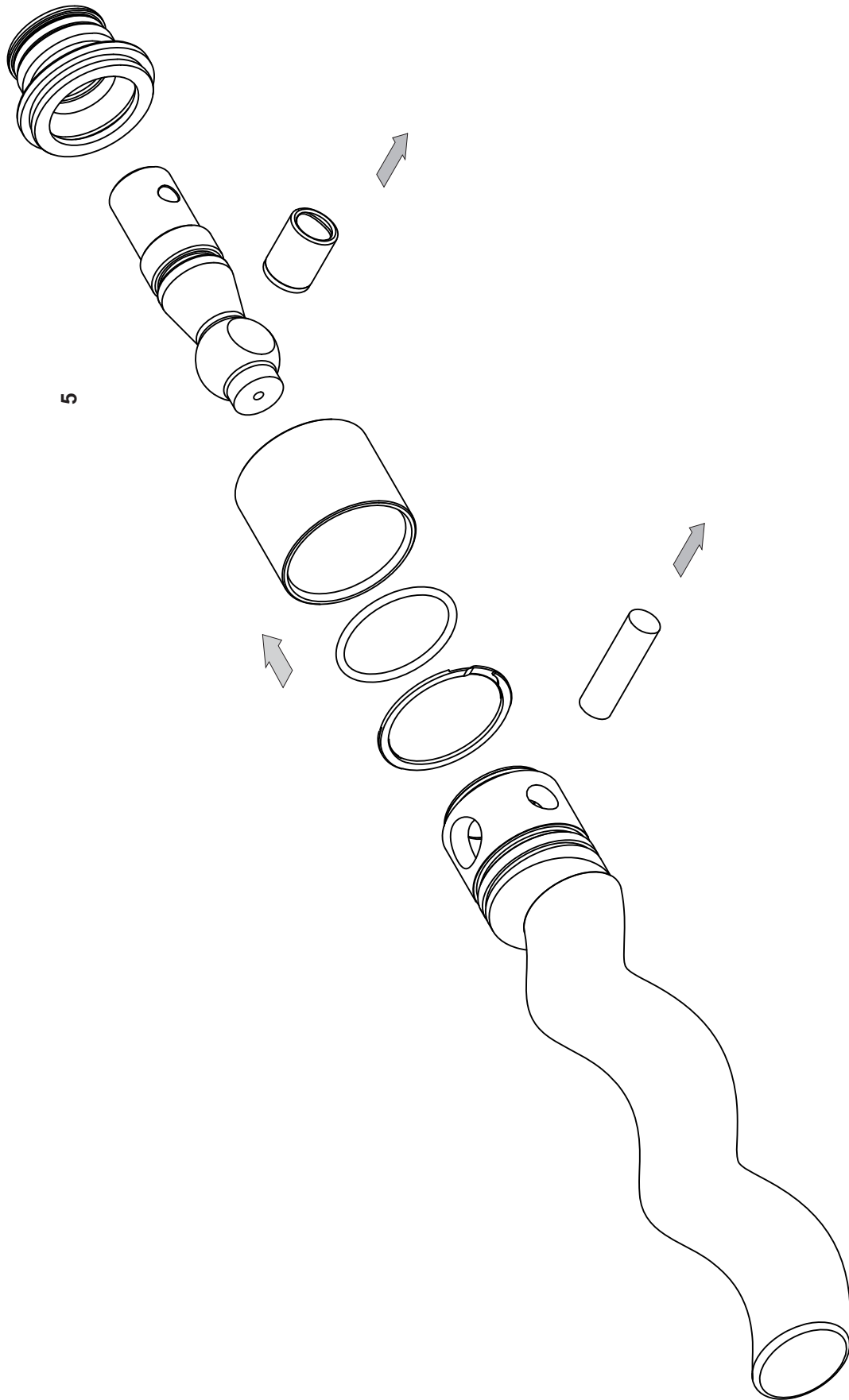

ROTOR & STATOR CHANGE
DISMANTLING

Dismantling & Assembly Diagrams

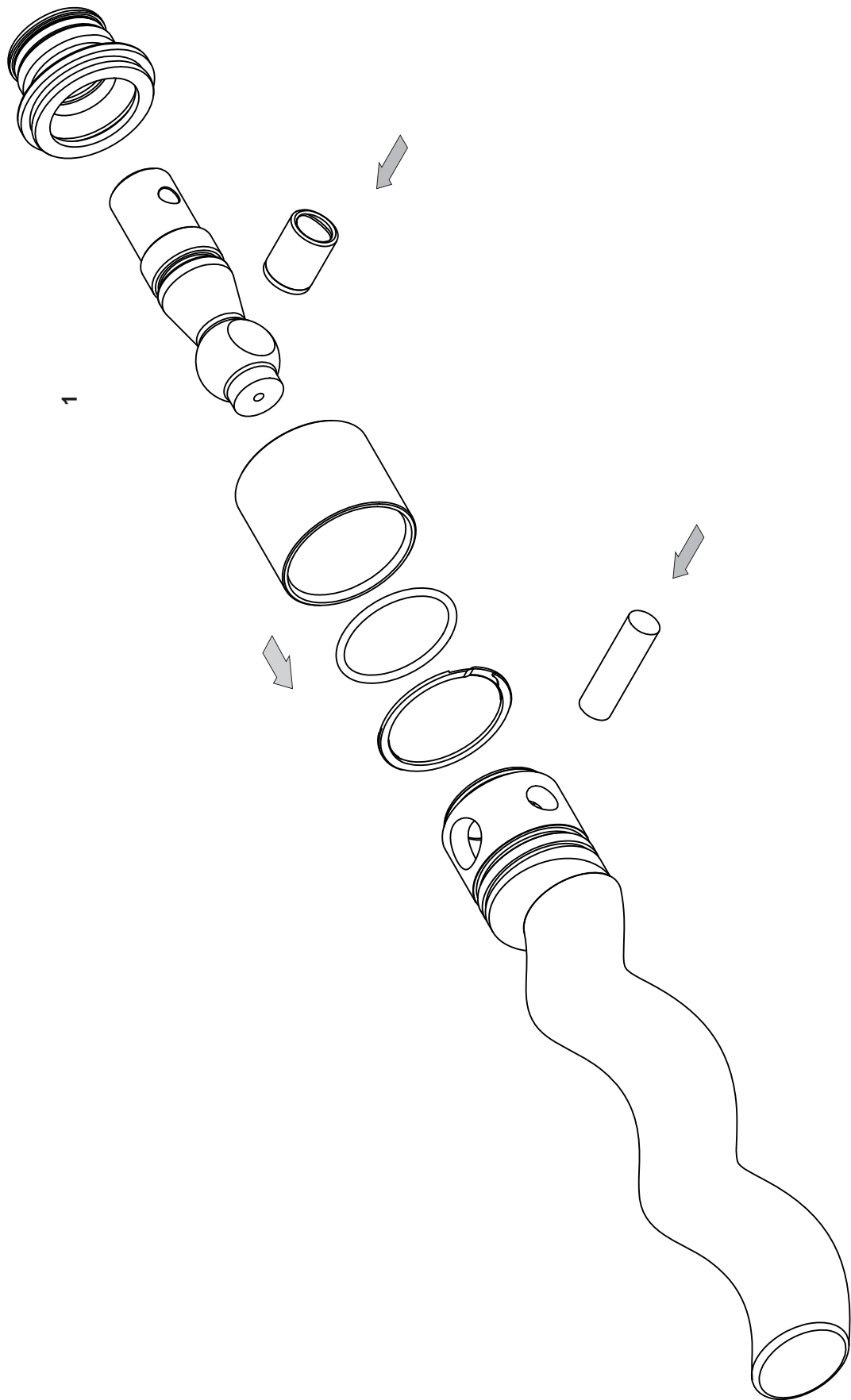

ROTOR & STATOR CHANGE
ASSEMBLY

Dismantling & Assembly Diagrams

ROTOR & STATOR CHANGE ASSEMBLY

2

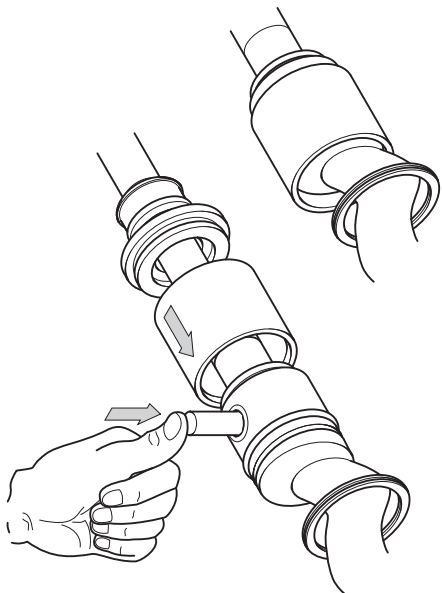

3

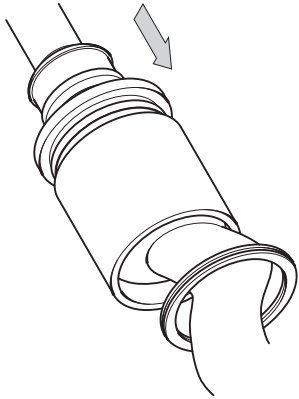

6

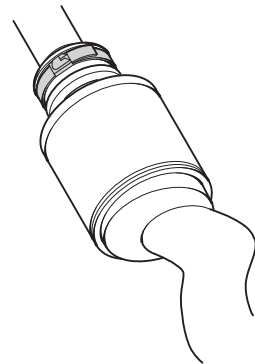

4

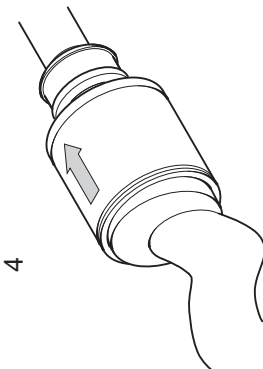

5

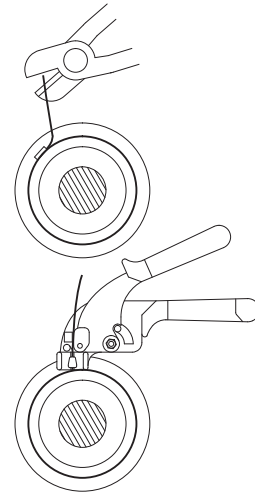
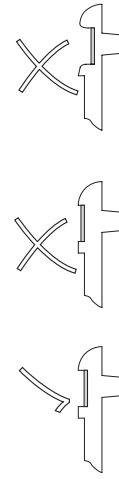
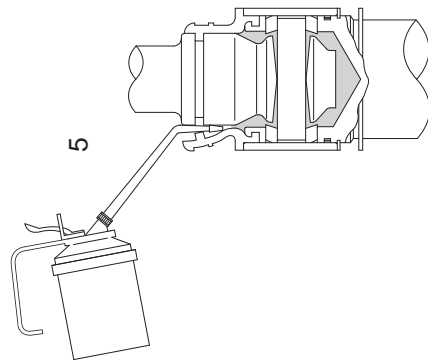

Correct tool available from Mono
Part Number: 80D1331

Dismantling & Assembly Diagrams

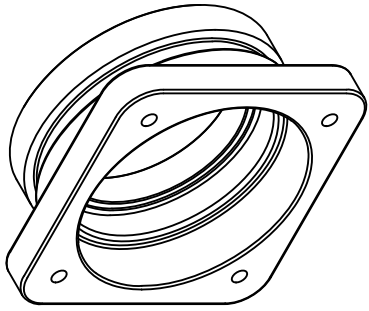

7

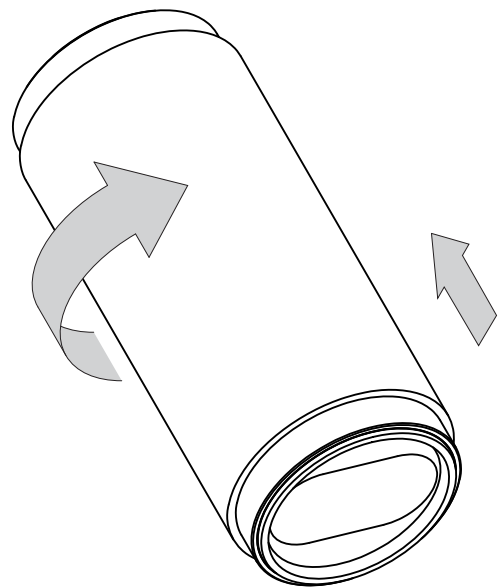
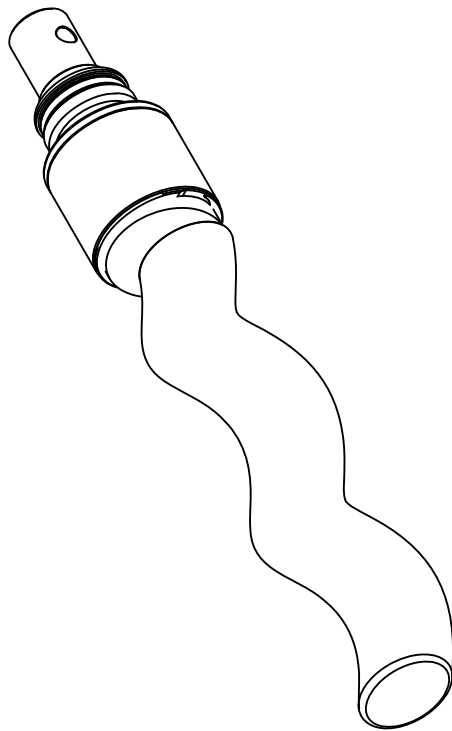

ROTOR & STATOR CHANGE
ASSEMBLY

Dismantling & Assembly Diagrams

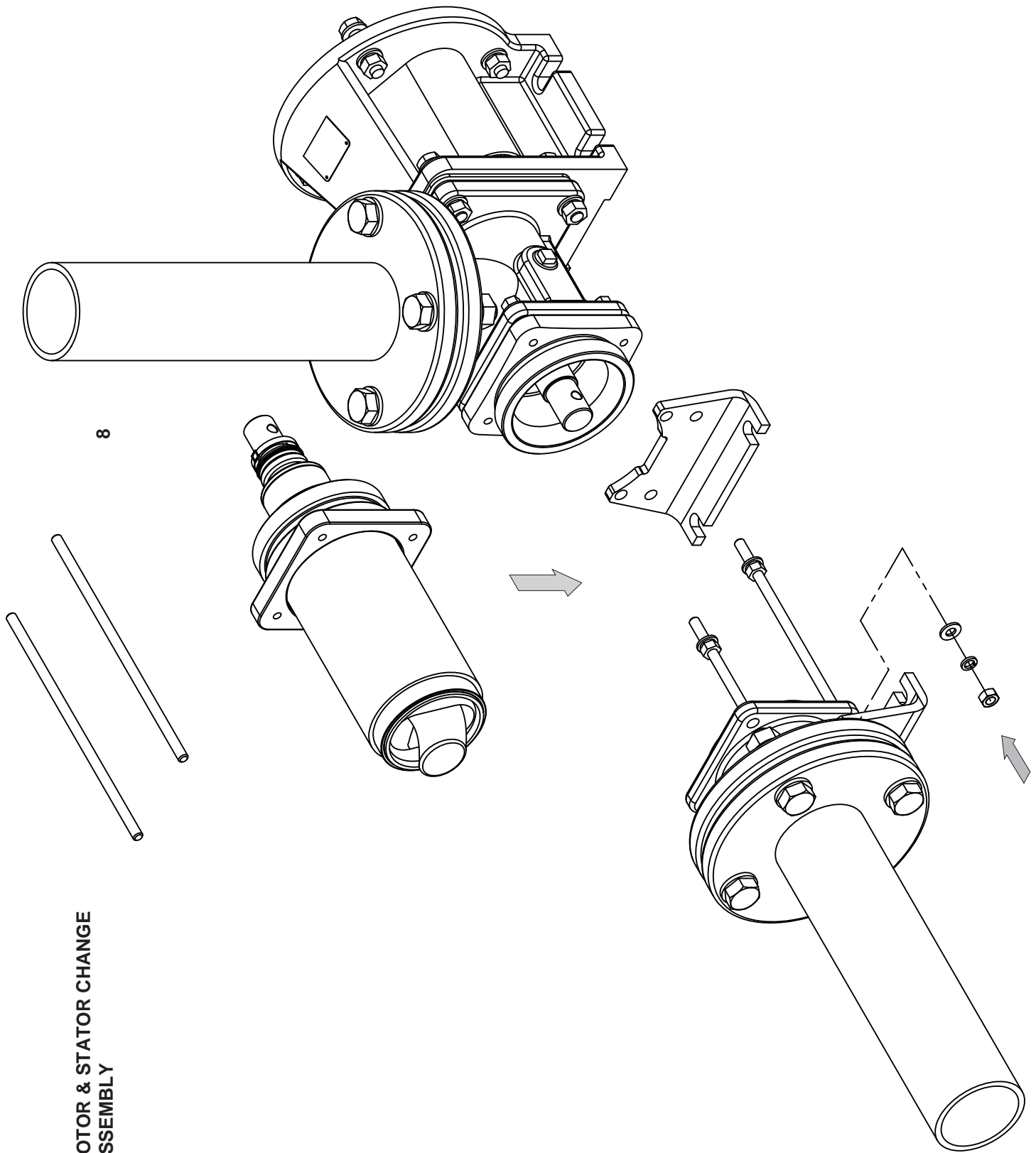

ROTOR & STATOR CHANGE
ASSEMBLY

Dismantling & Assembly Diagrams

ROTOR & STATOR CHANGE
ASSEMBLY

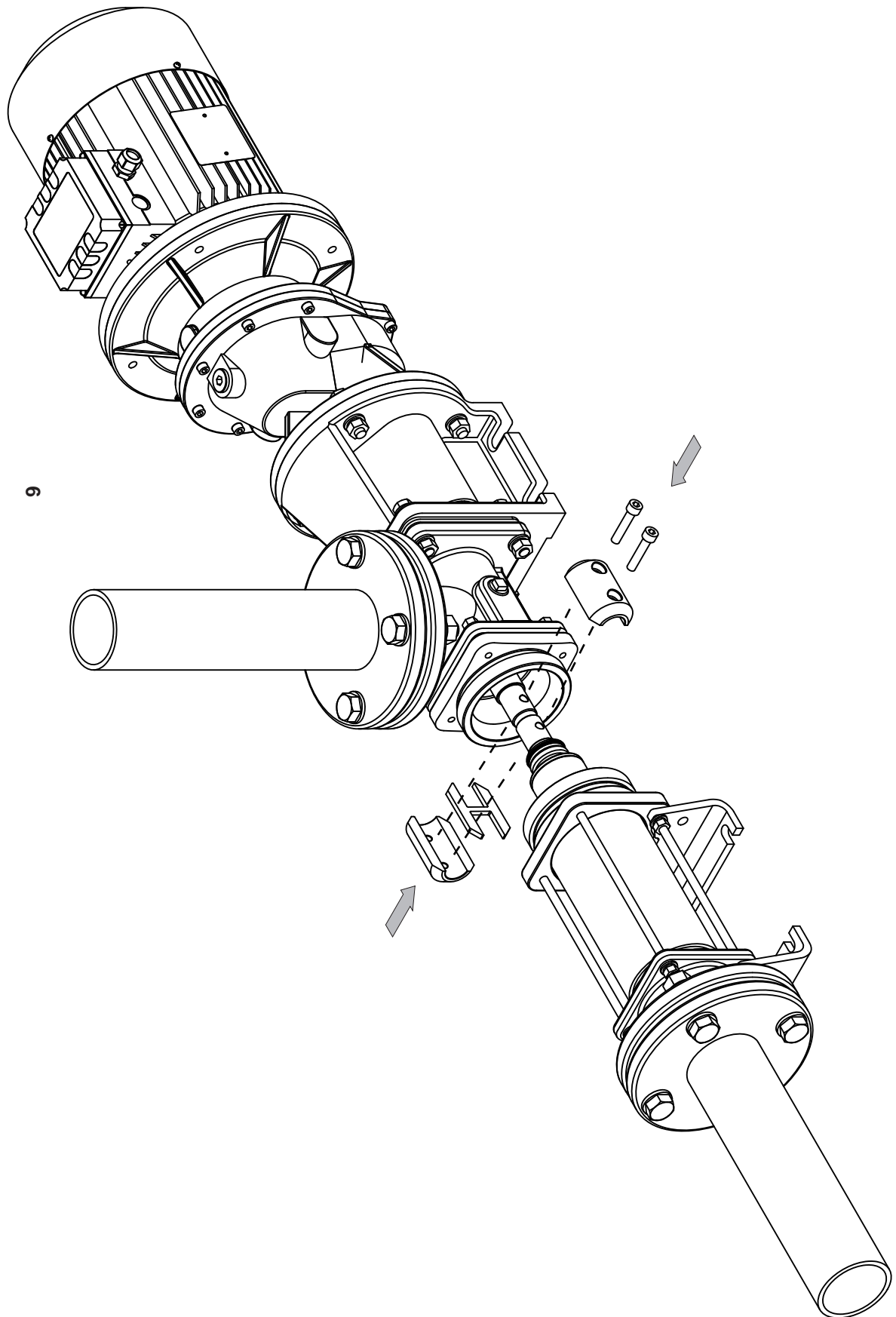

Dismantling & Assembly Diagrams

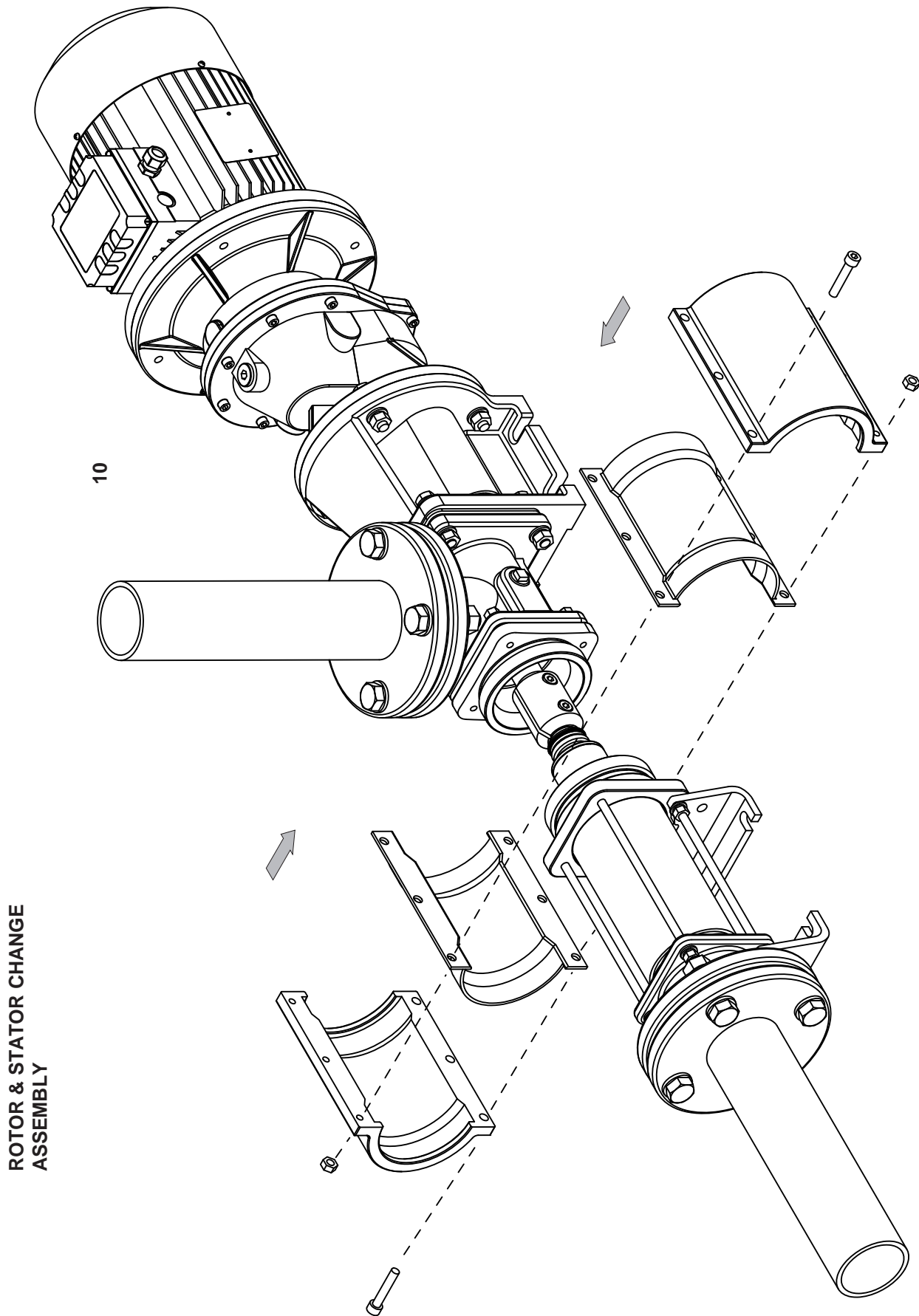

Dismantling & Assembly Diagrams

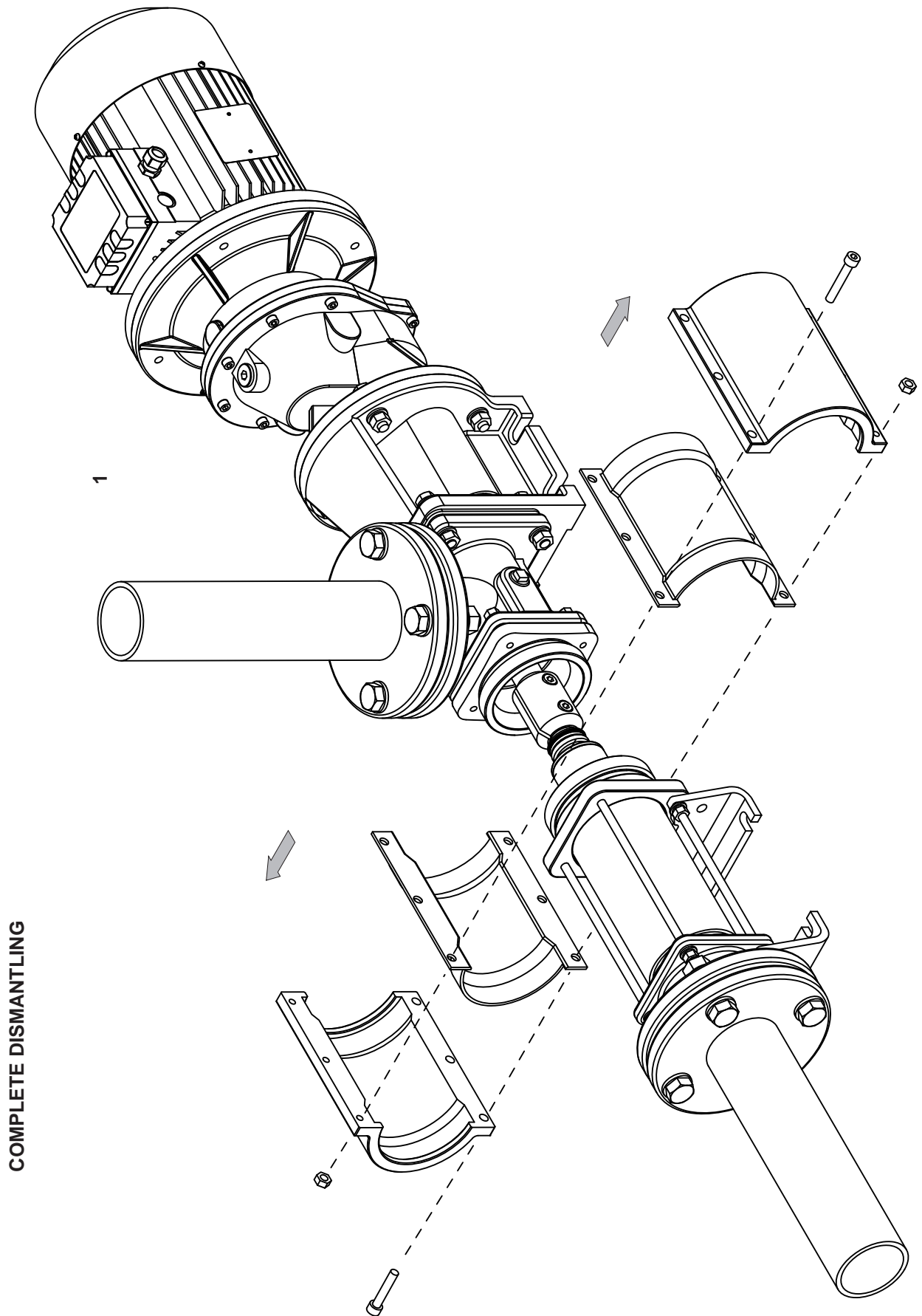

Dismantling & Assembly Diagrams

COMPLETE DISMANTLING

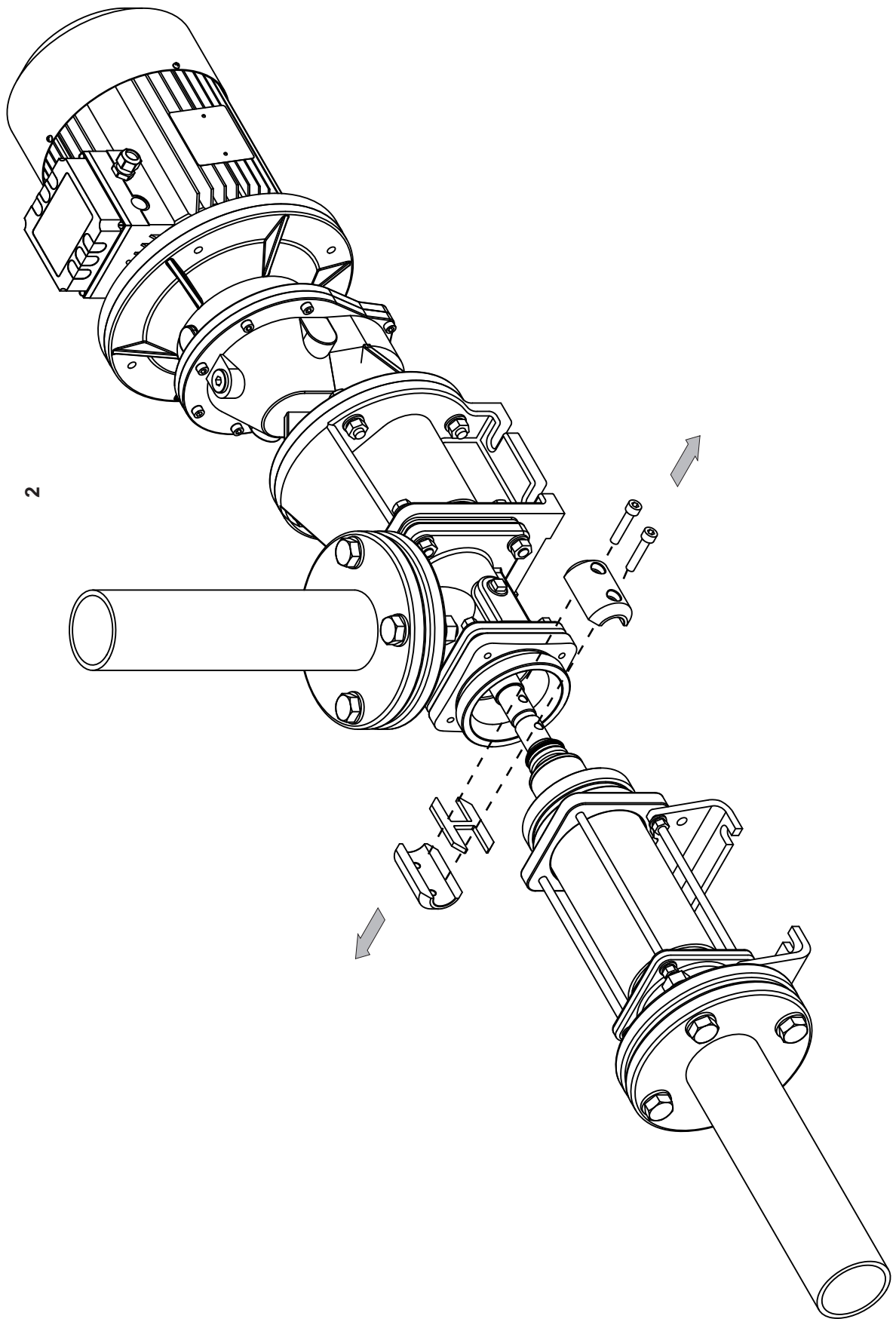

Dismantling & Assembly Diagrams

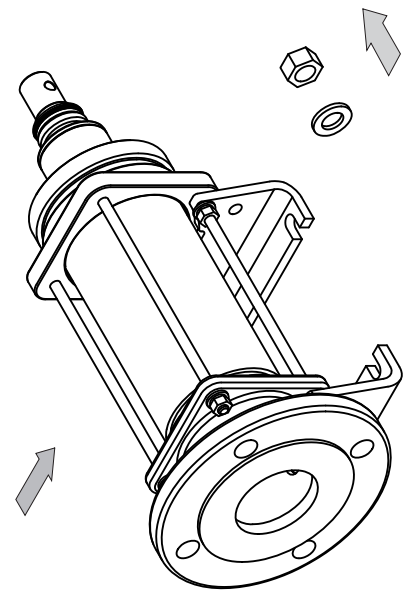
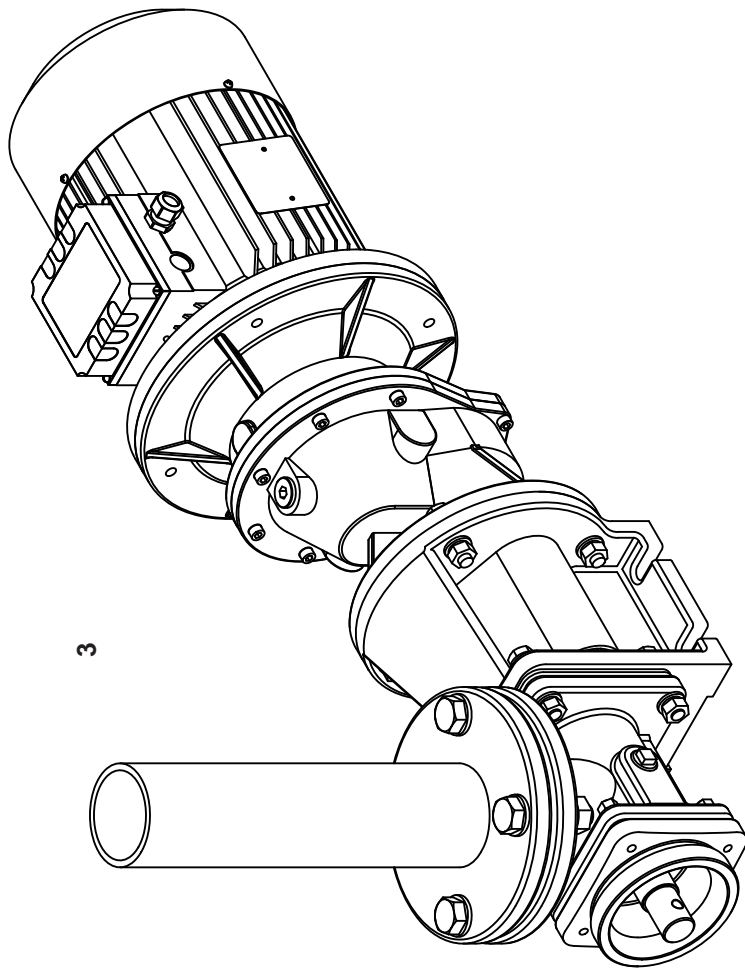

COMPLETE DISMANTLING

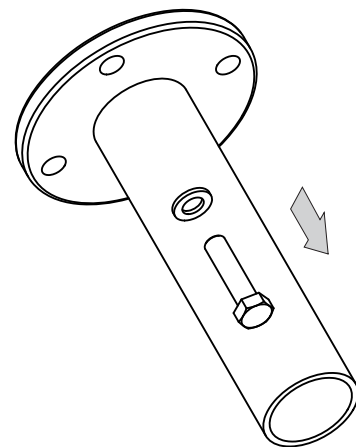

Dismantling & Assembly Diagrams

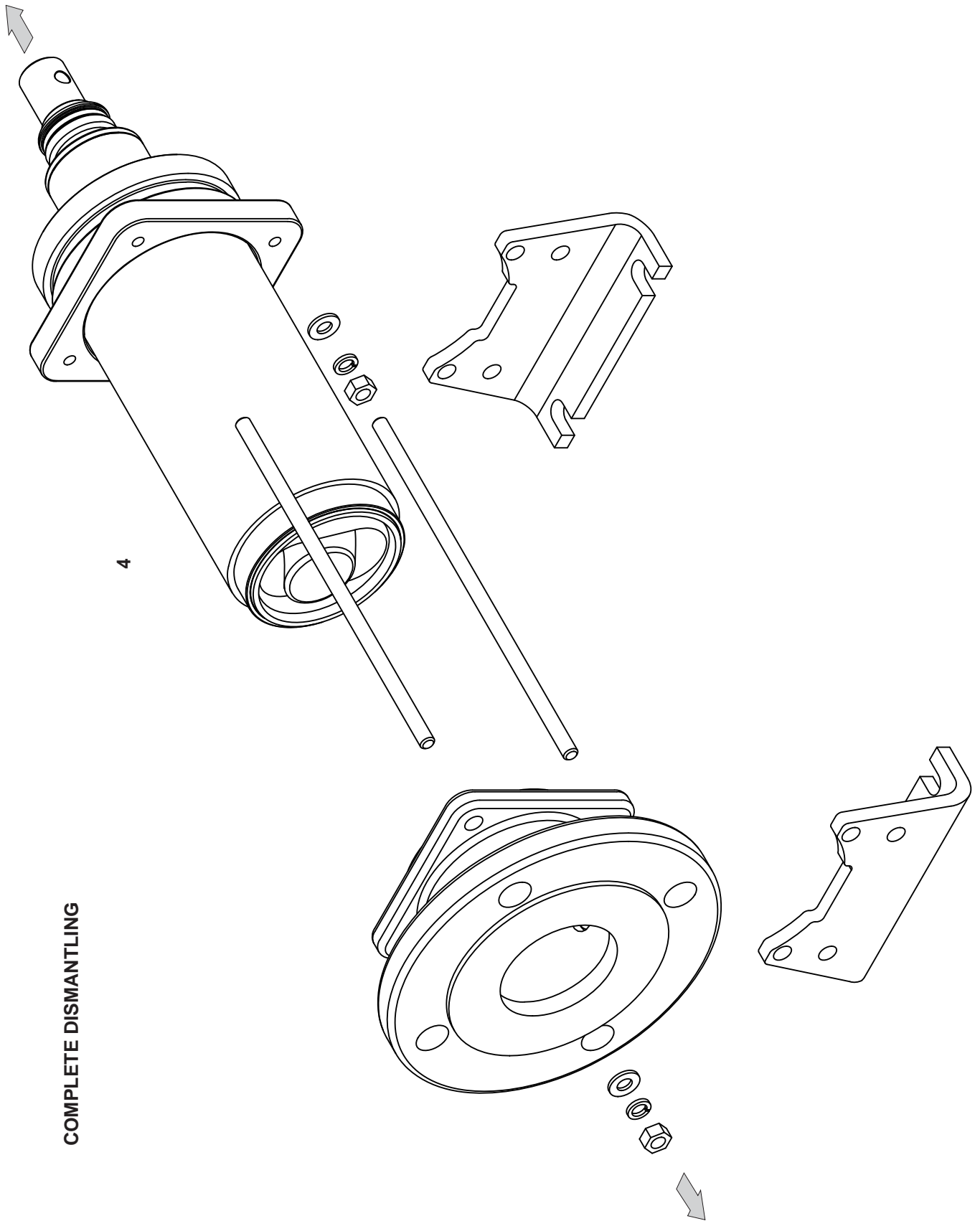

COMPLETE DISMANTLING

Dismantling & Assembly Diagrams

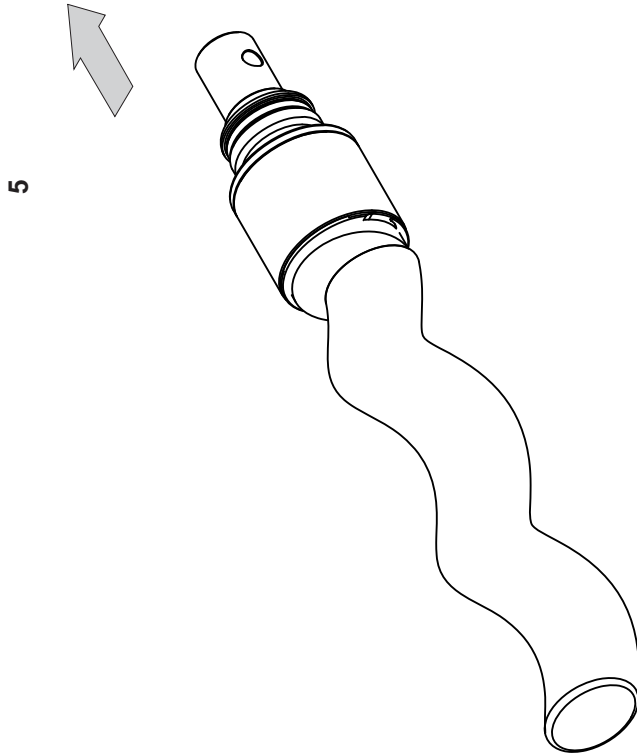
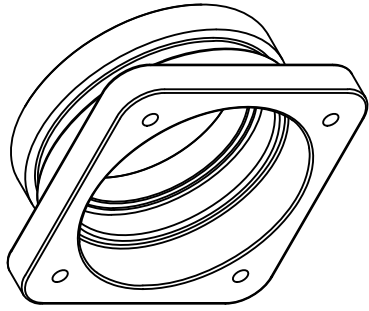

5

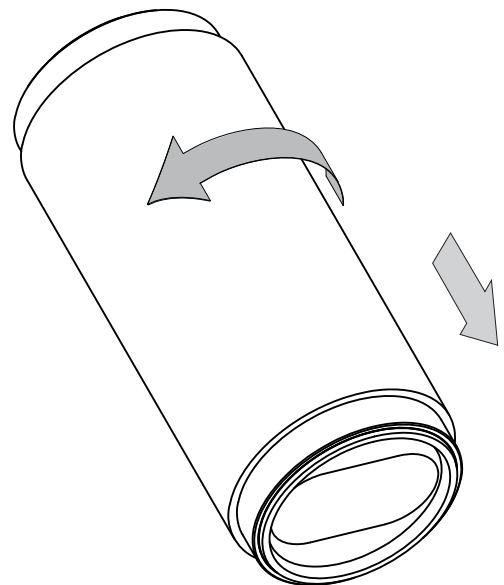

COMPLETE DISMANTLING

Dismantling & Assembly Diagrams

COMPLETE DISMANTLING

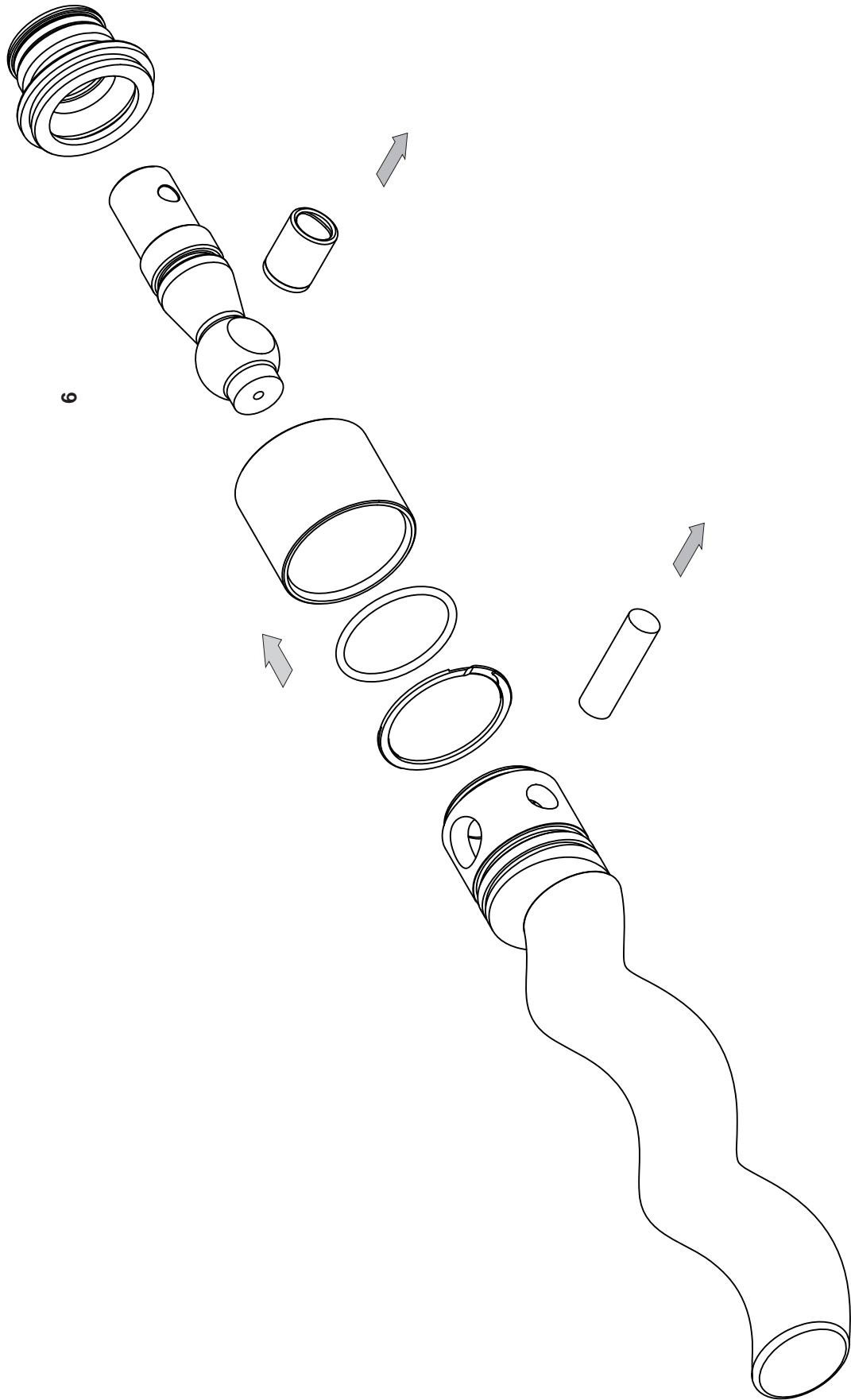

Dismantling & Assembly Diagrams

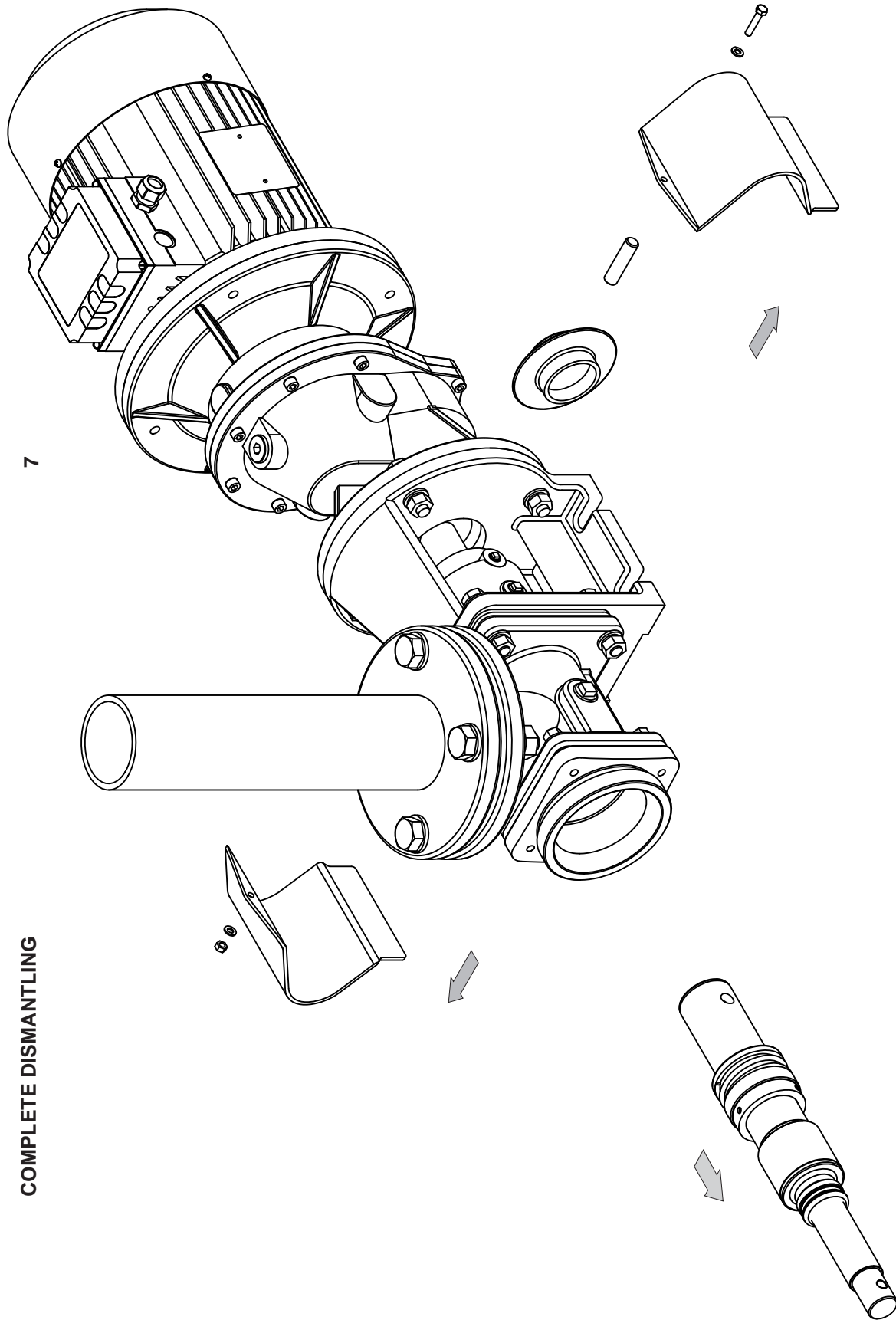

Dismantling & Assembly Diagrams

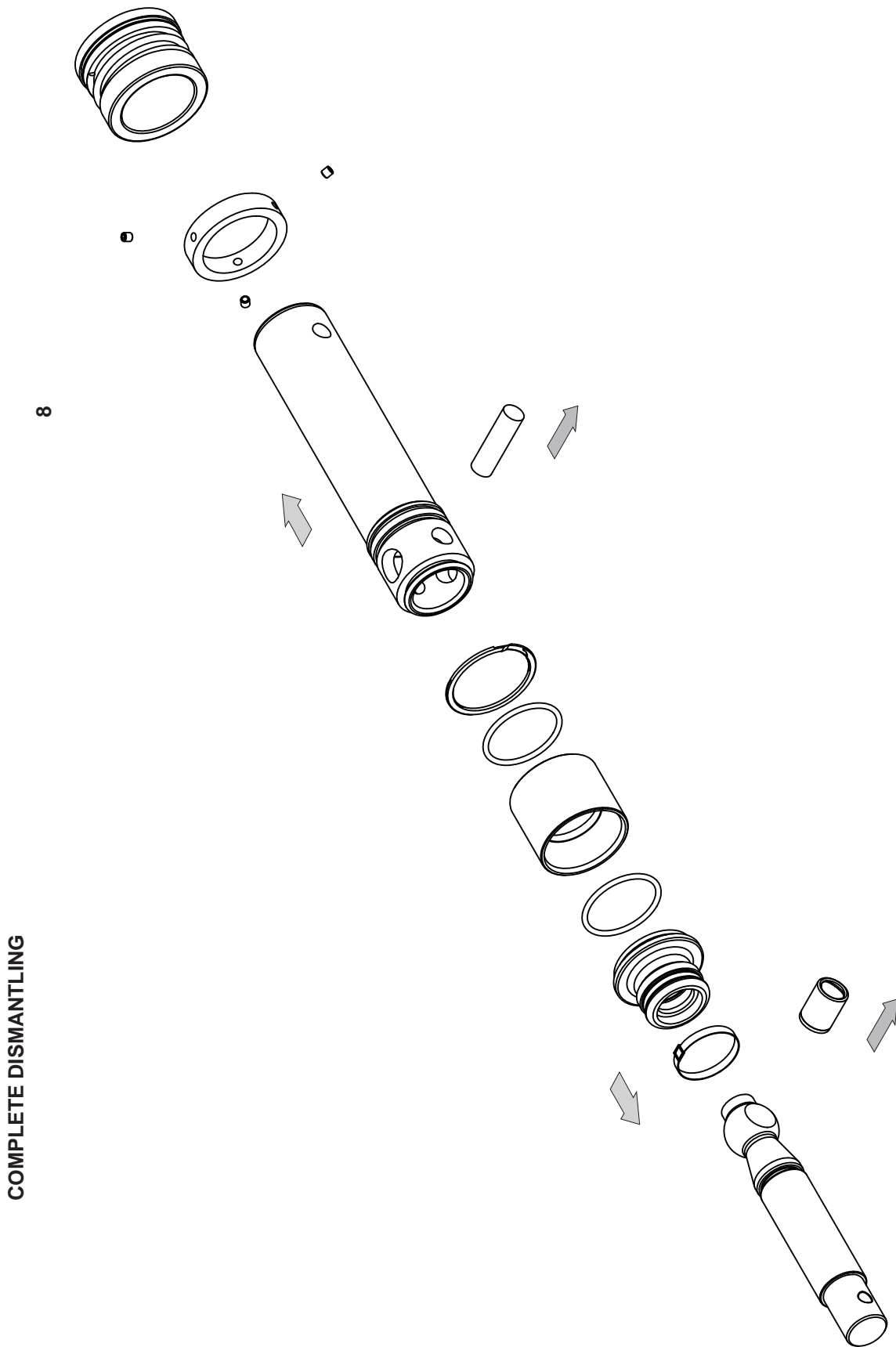

Dismantling & Assembly Diagrams

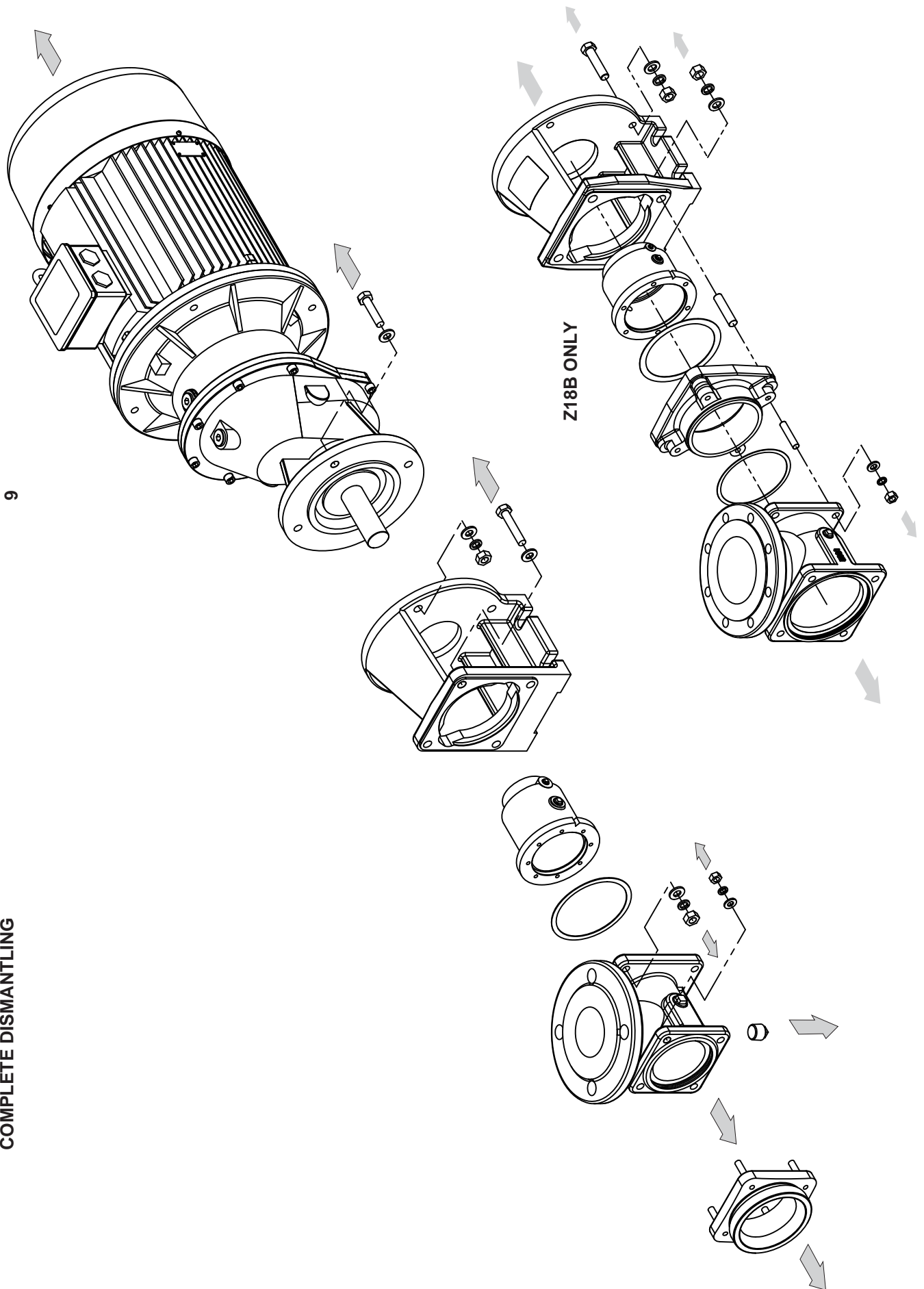

Dismantling & Assembly Diagrams

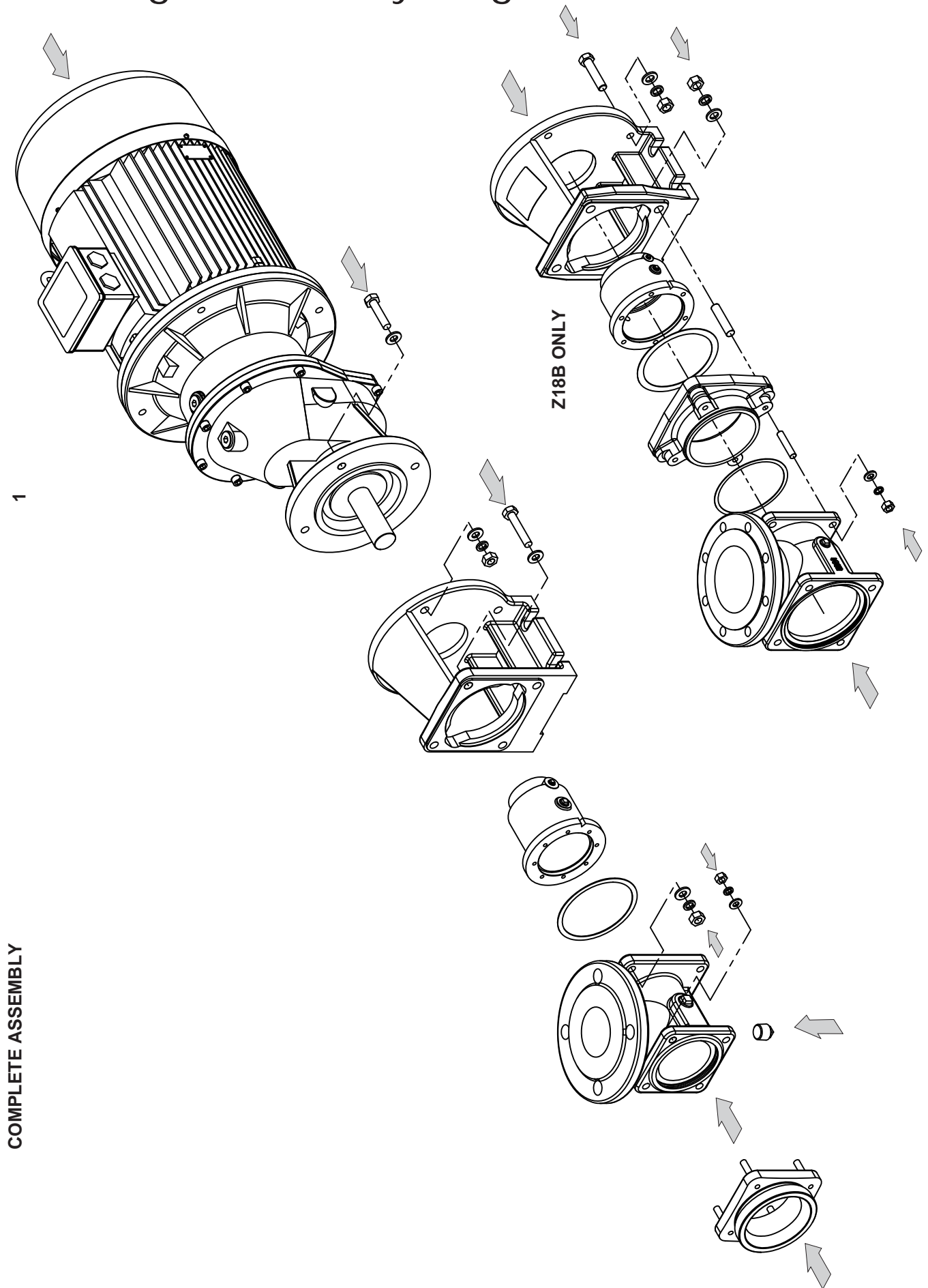

COMPLETE ASSEMBLY

Dismantling & Assembly Diagrams

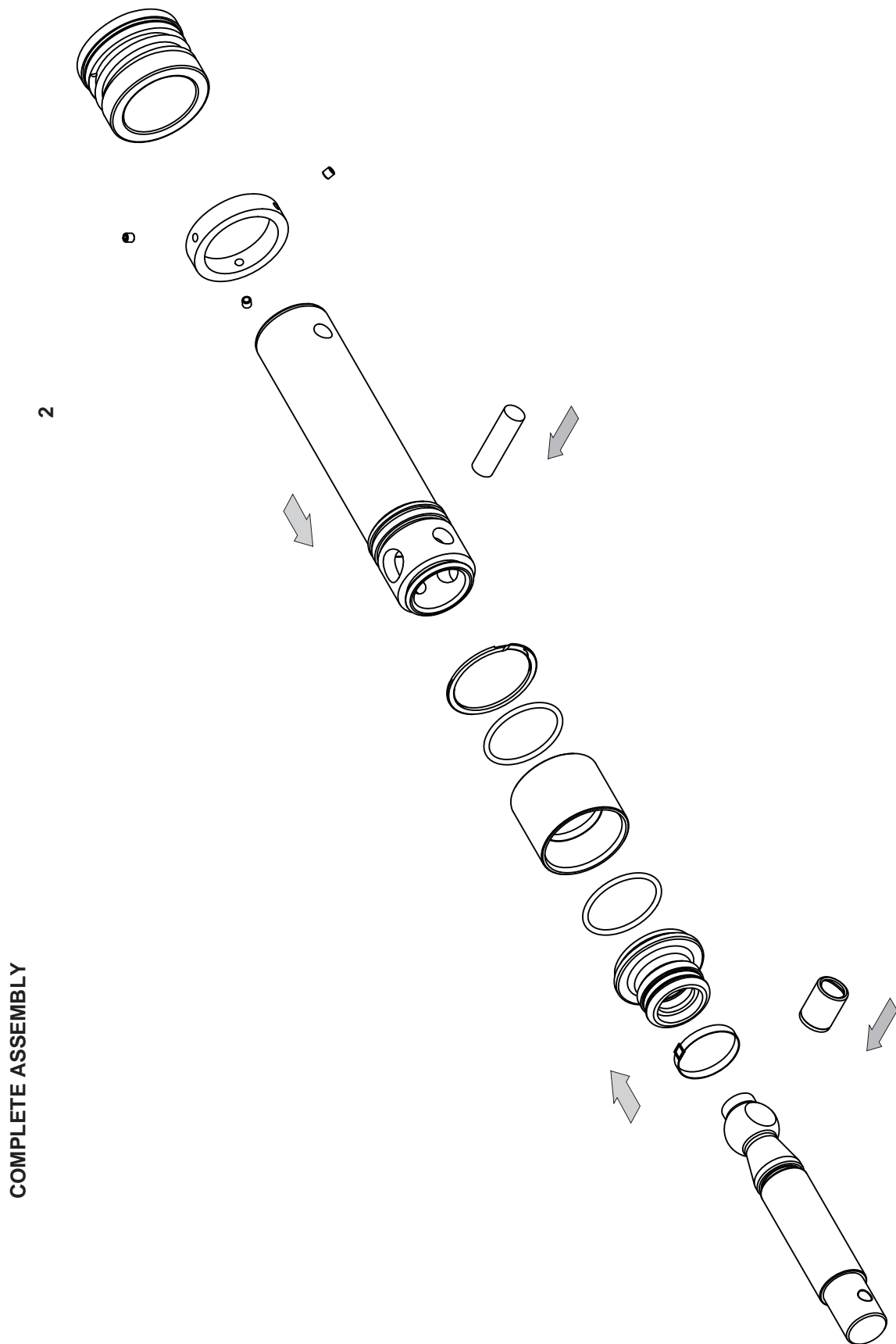

Dismantling & Assembly Diagrams

Correct tool available from Mono
Part Number: 80D1331

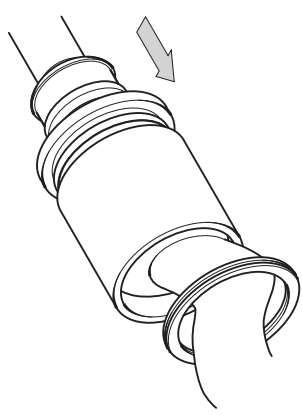
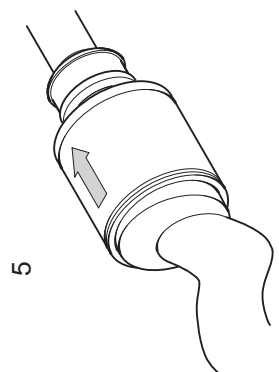
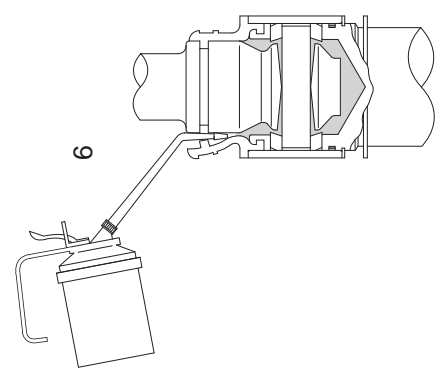
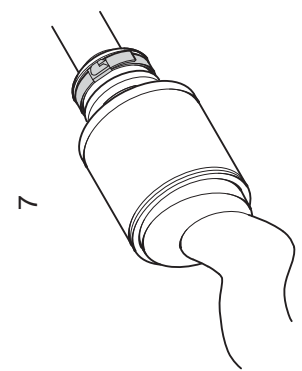
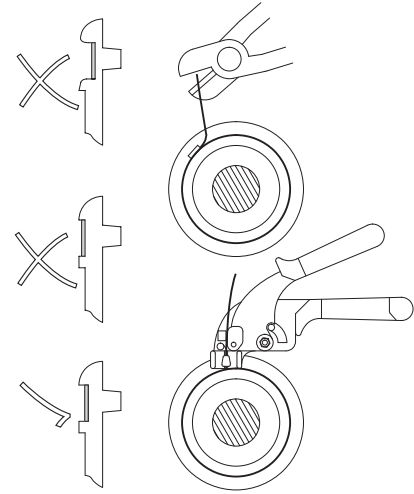

FULL PUMP ASSEMBLY

3

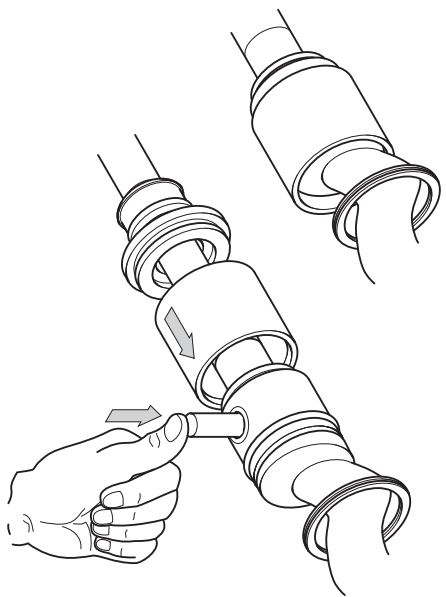

Dismantling & Assembly Diagrams

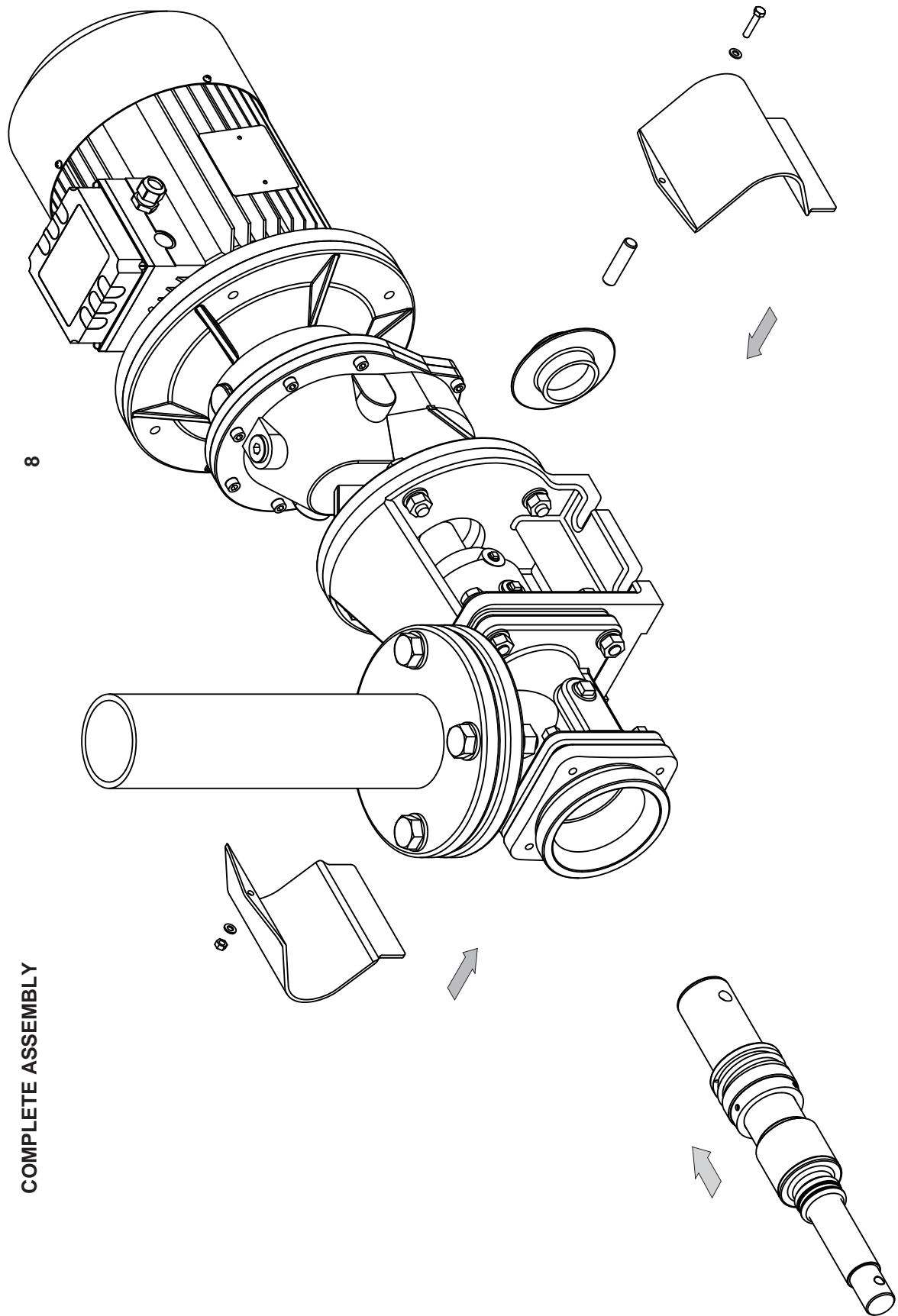

Dismantling & Assembly Diagrams

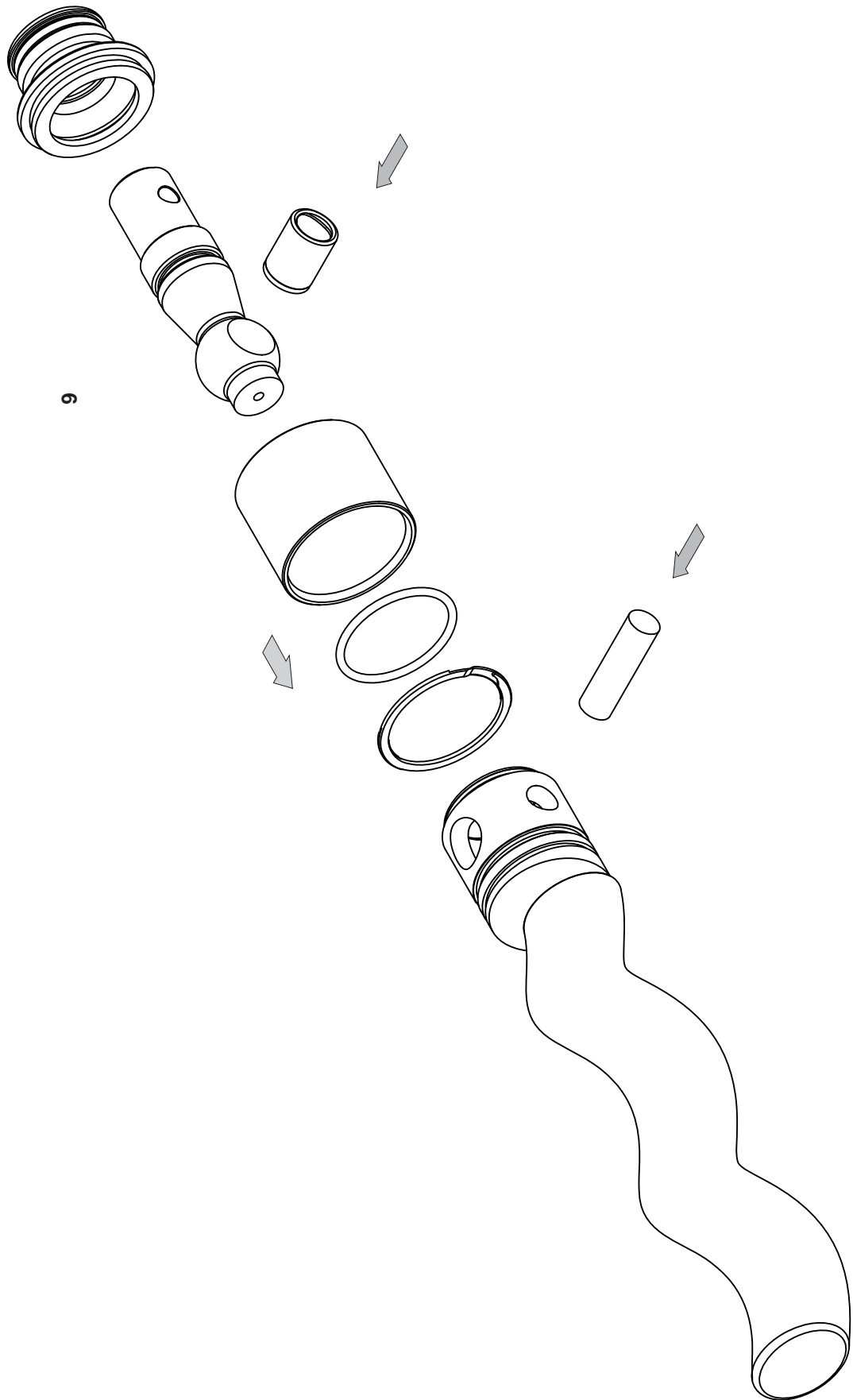

COMPLETE ASSEMBLY

Dismantling & Assembly Diagrams

Correct tool available from Mono
Part Number: 80D1331

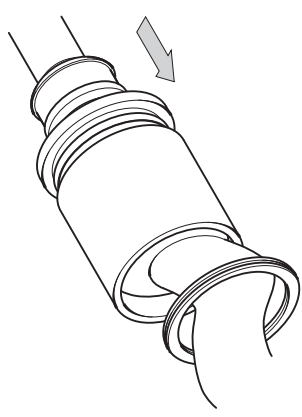
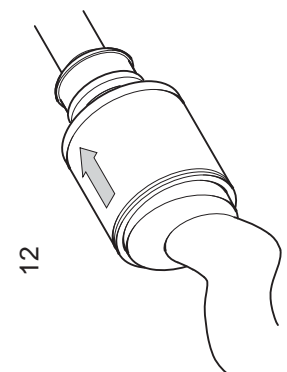
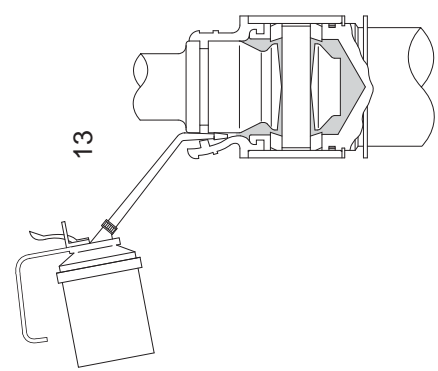
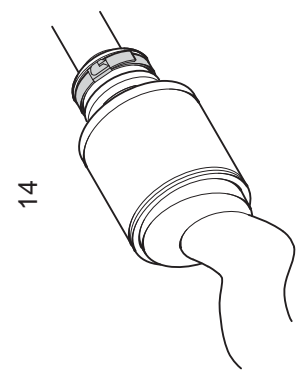
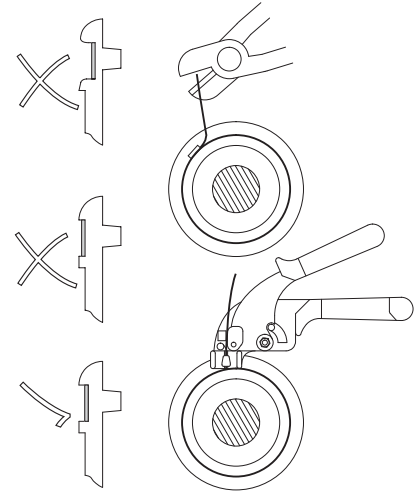

FULL PUMP ASSEMBLY

10

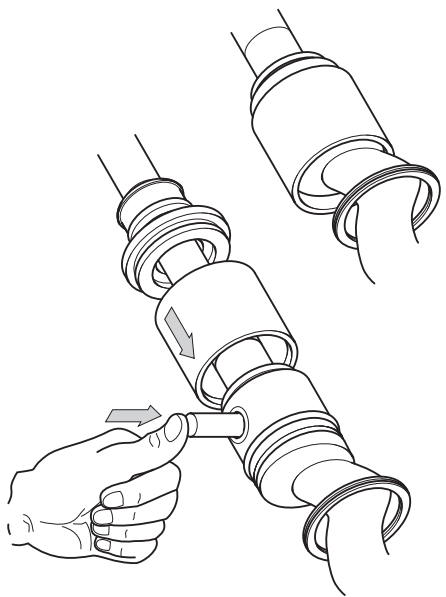

11



One Company, Unlimited Solutions

Dismantling & Assembly Diagrams

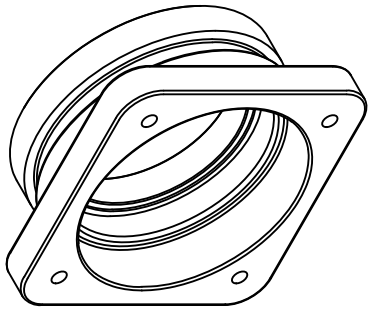

15

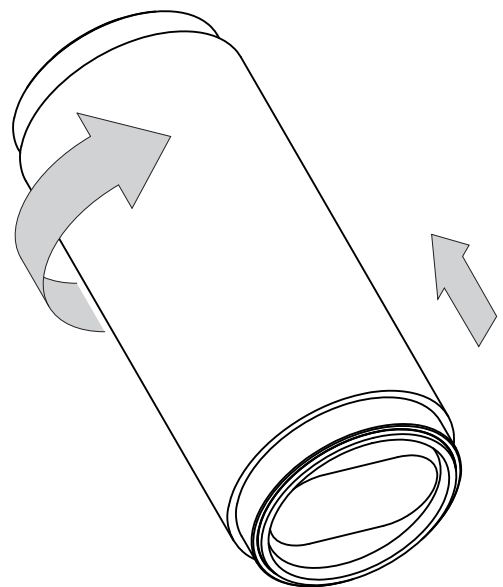
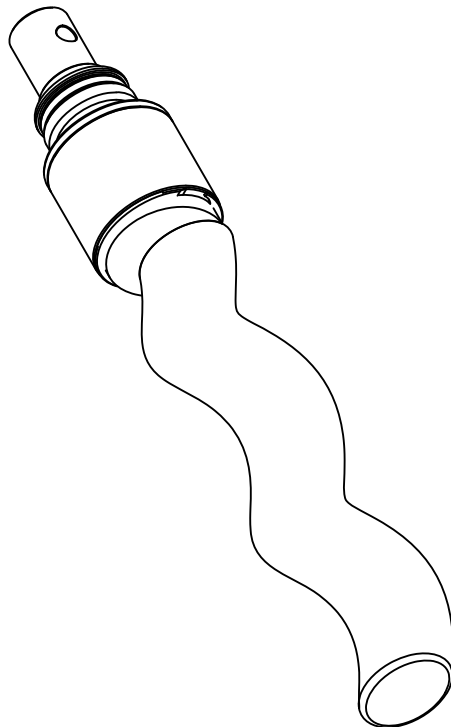

COMPLETE ASSEMBLY

Dismantling & Assembly Diagrams

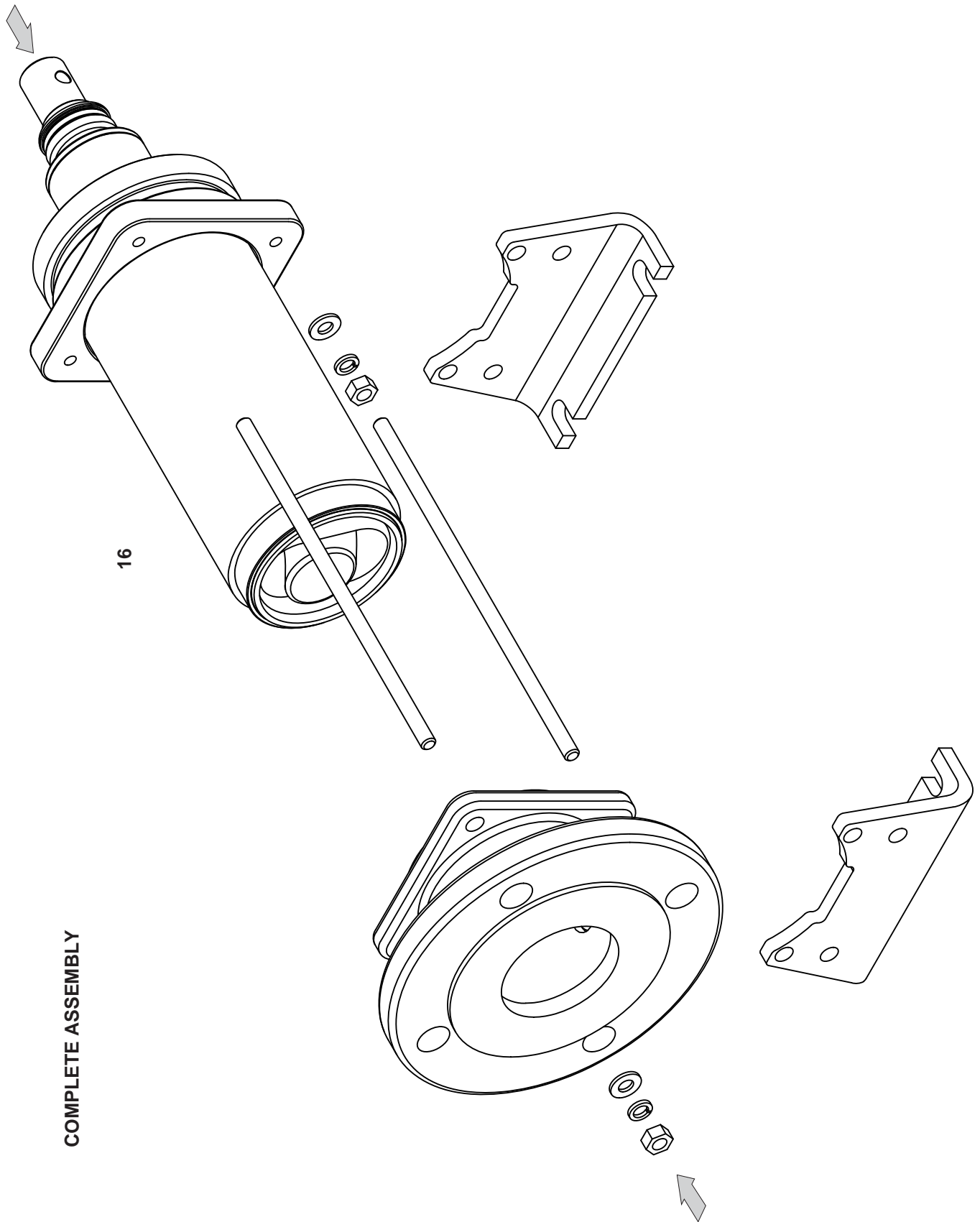

Dismantling & Assembly Diagrams

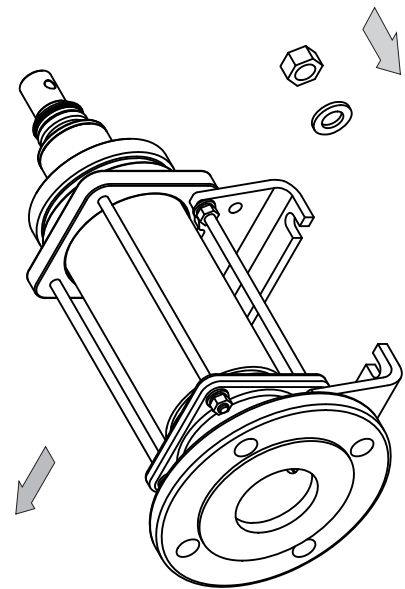
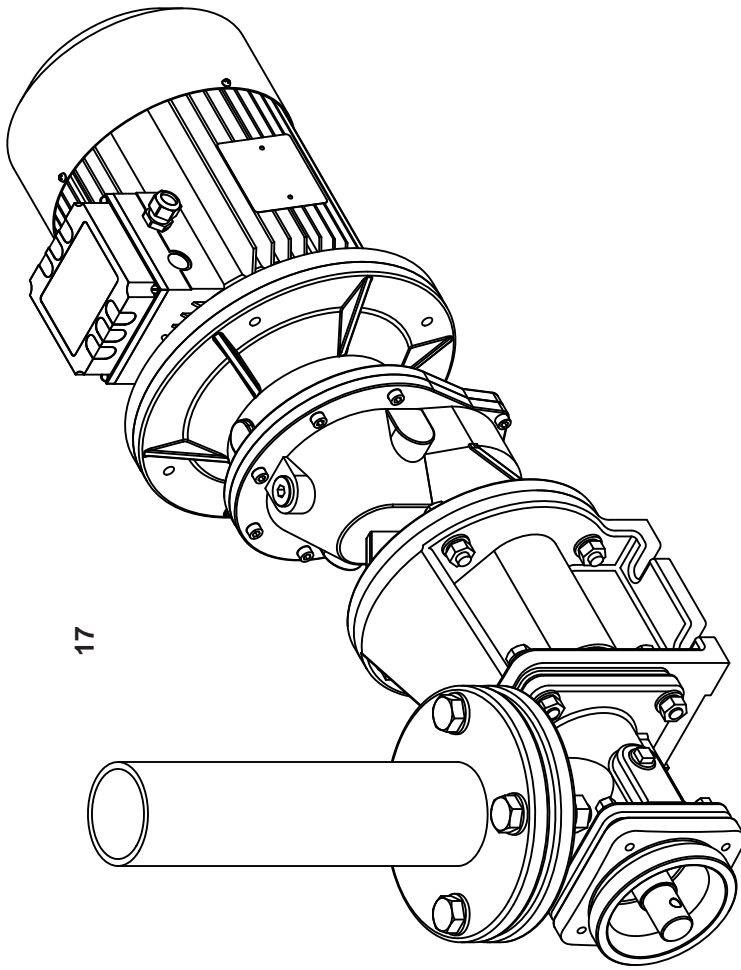

COMPLETE ASSEMBLY

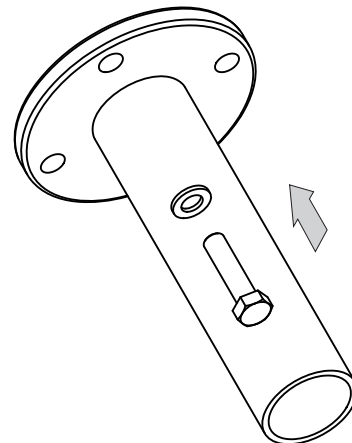

Dismantling & Assembly Diagrams

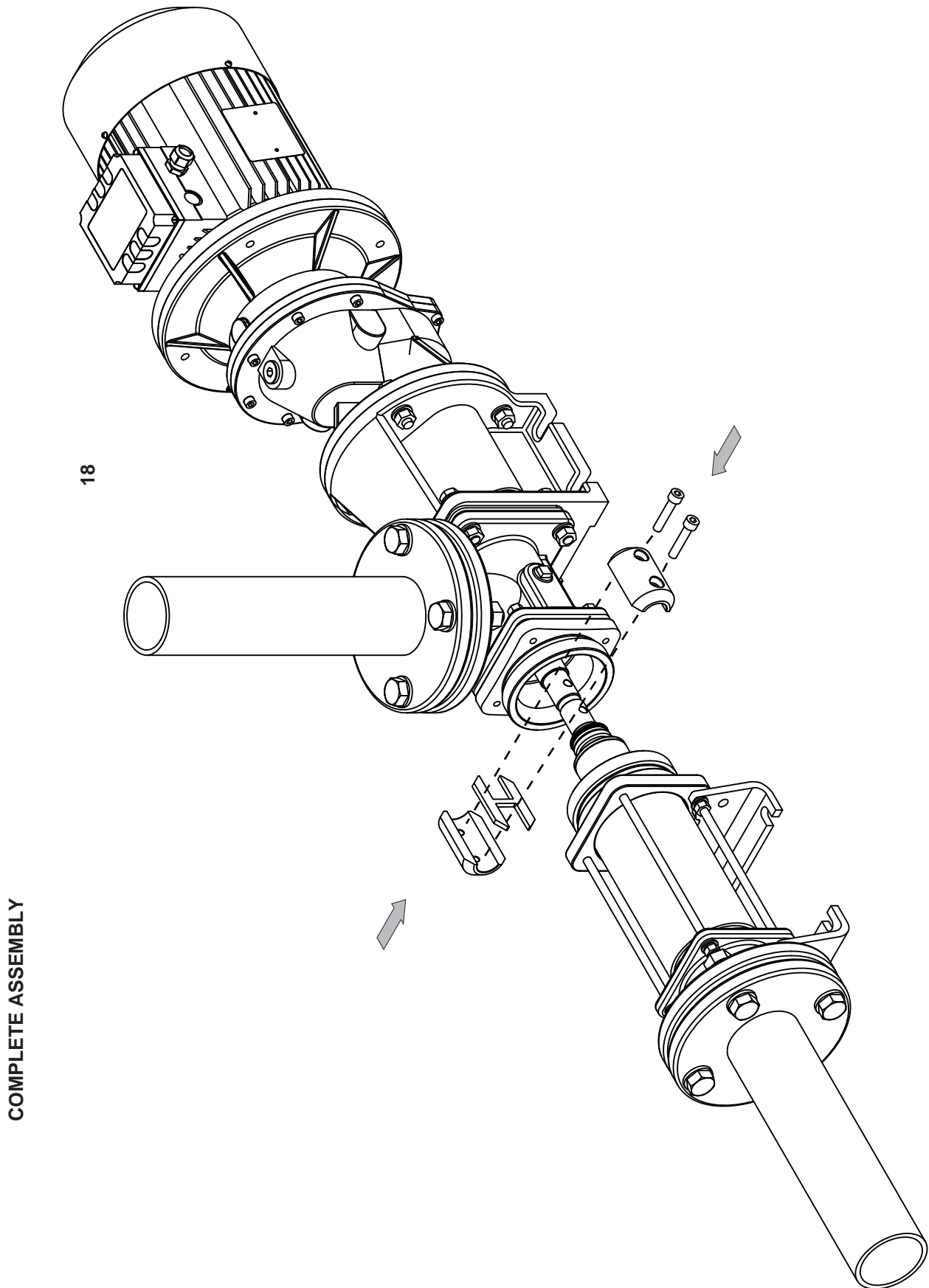

Dismantling & Assembly Diagrams

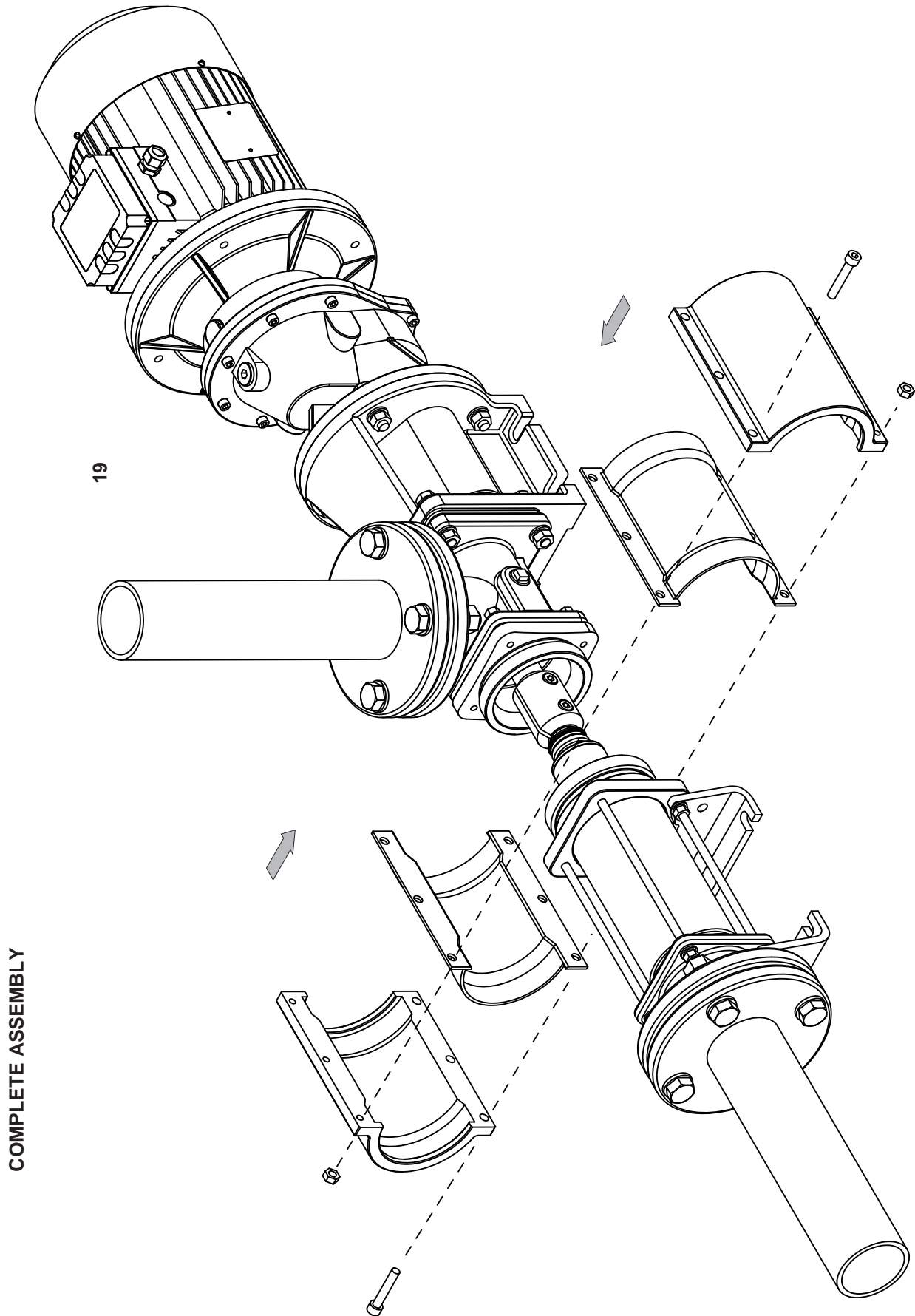

Setting Length - Mechanical Seal

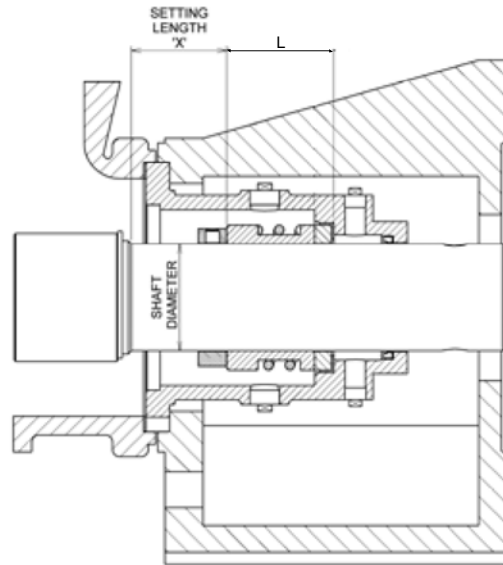

Pump Size	Drive Type	Shaft Diameter mm	Seal Part No	Seal Working Length L mm	Setting Distance 'X' mm
Z14A	Pin Joint	45	M045139G	45.0	41
Z14B					
Z14K					
Z15A					
Z15K					
Z15B	Pin Joint	55	M055139G	47.5	34.5
Z16A					
Z16K					
Z16B	Pin Joint	65	M065139G	52.5	33.5
Z17A					
Z17B					
Z17K					
Z18A					
Z18K	Pin Joint	85	M085139G	60.0	33
Z18B					
Z19A					
Z19B					
Z19K					
Z1AA					
Z1AK					

NOTE: All seal working lengths are to DIN L1K dimensions.

This table is not to be used for standard or DIN L1N working length seals.

All seals use 'M' type seat except for 85mm which uses 'BS' type or 'M' type.

This table is not necessarily compatible with any other seal type - check with Mono Pumps Technical Dept.

Exploded Views - Packed Gland

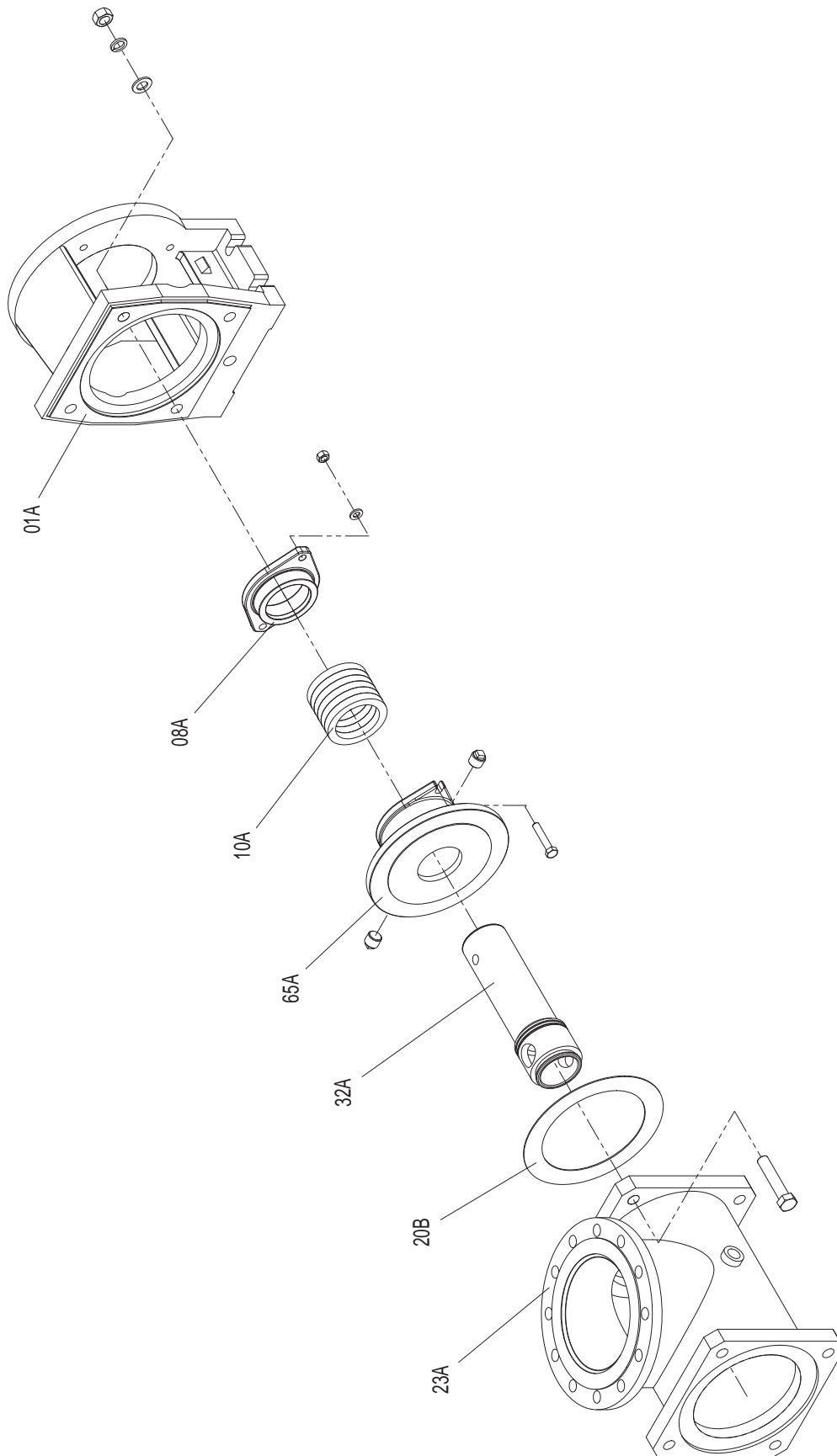

Exploded Views

BEARING HOUSING ONLY

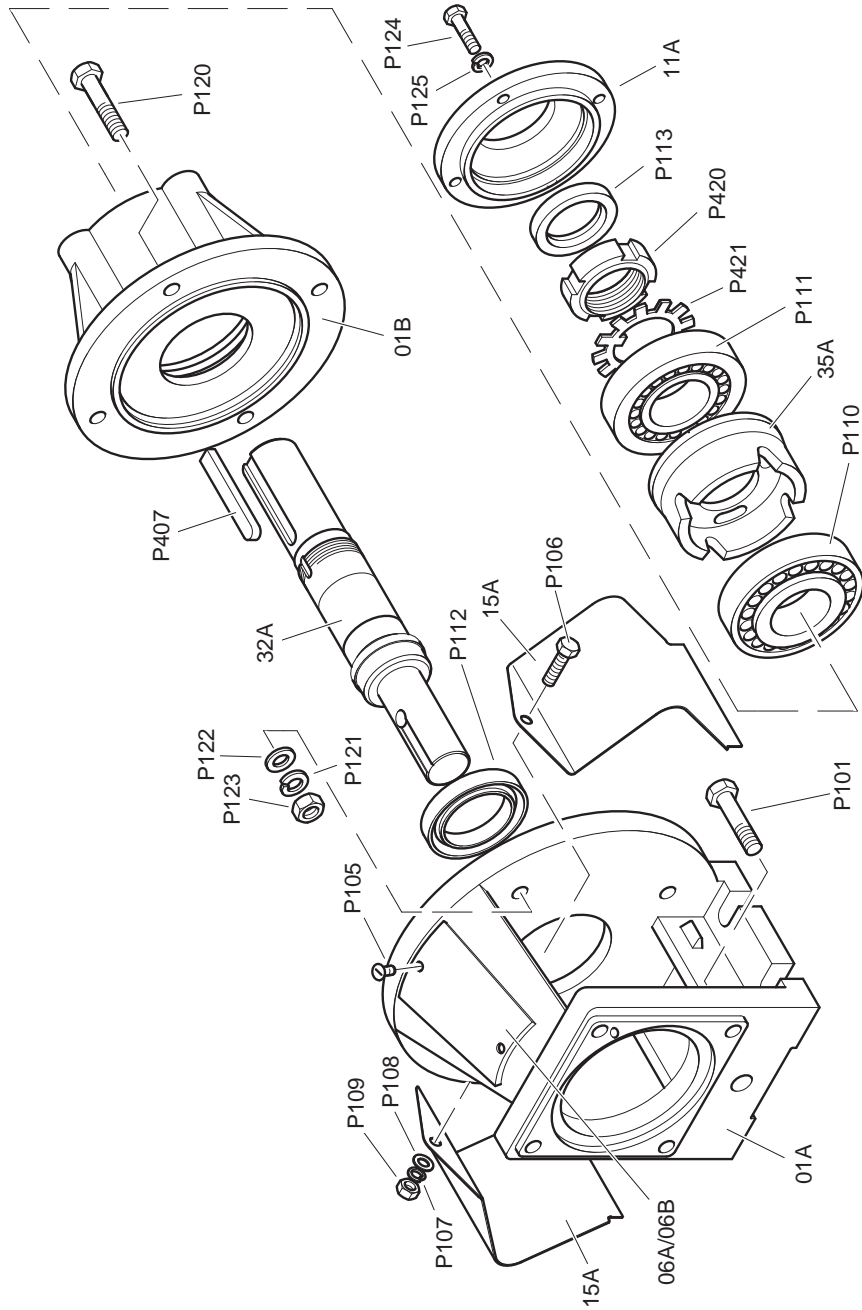

Exploded View

Z18B ONLY

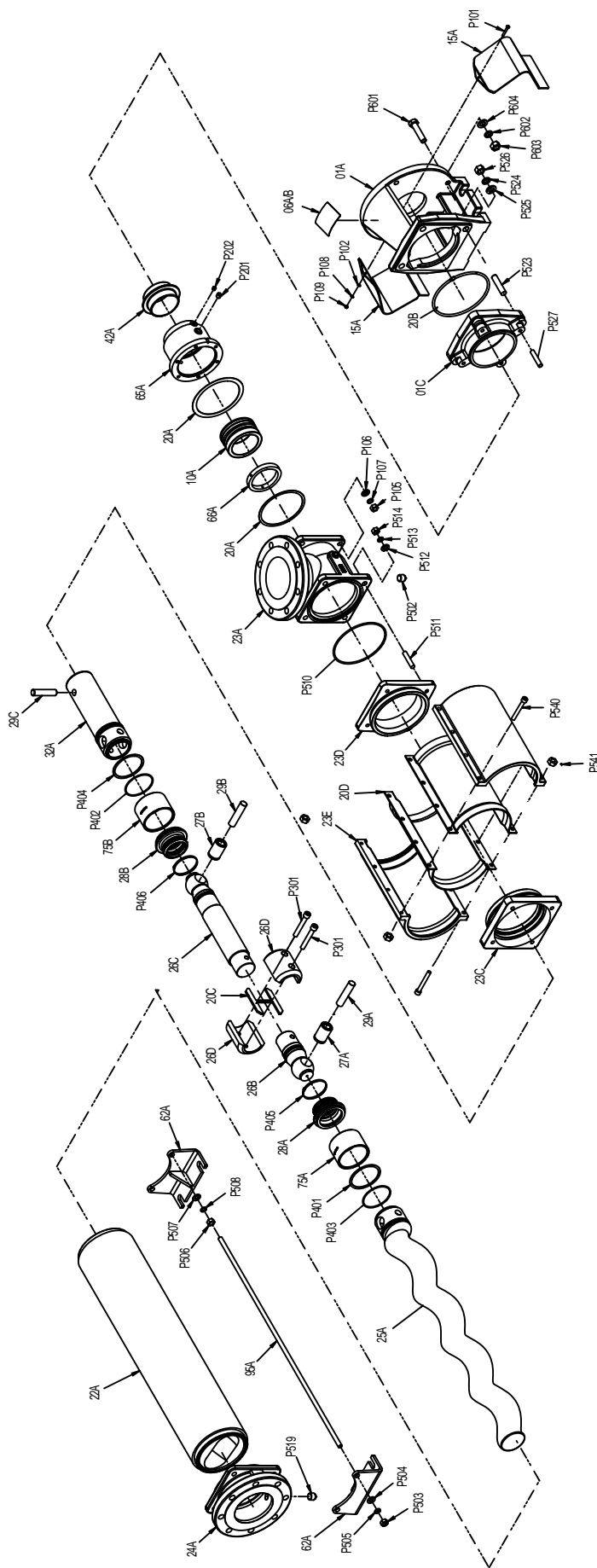

Exploded View

Z19A AND ABOVE

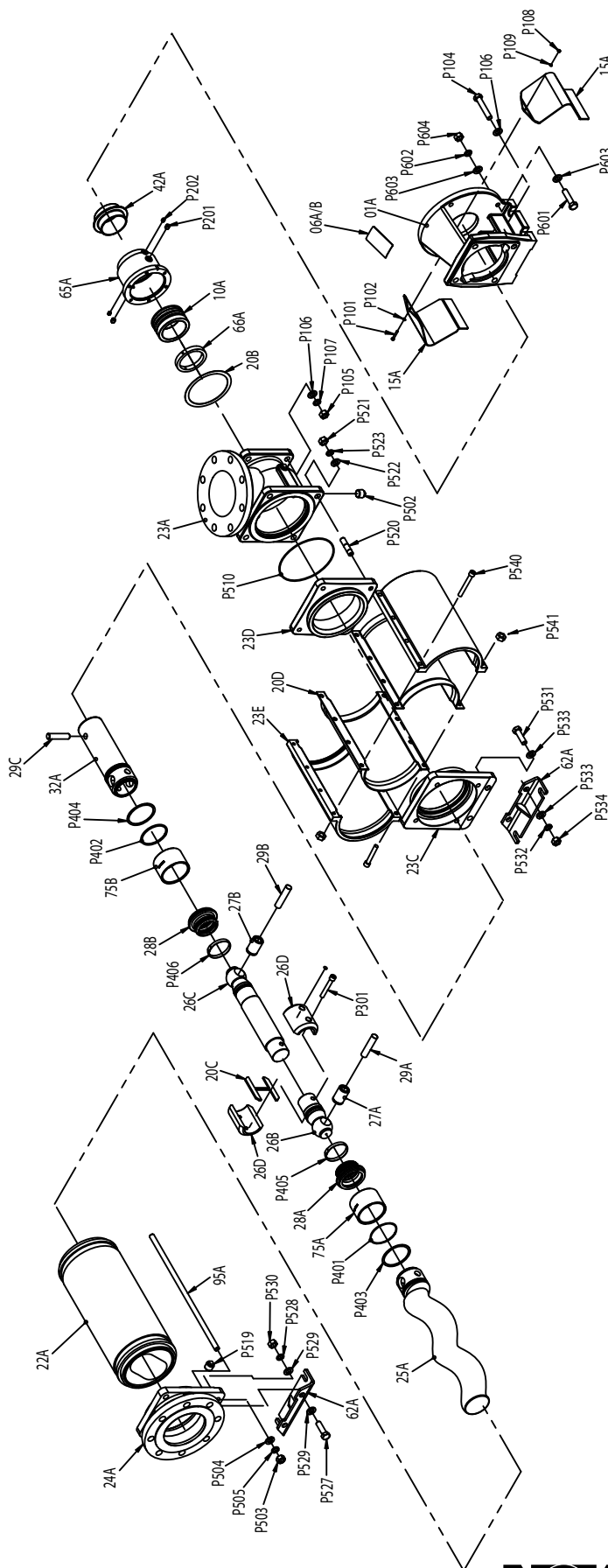

Drive Shaft Assembly with Plug

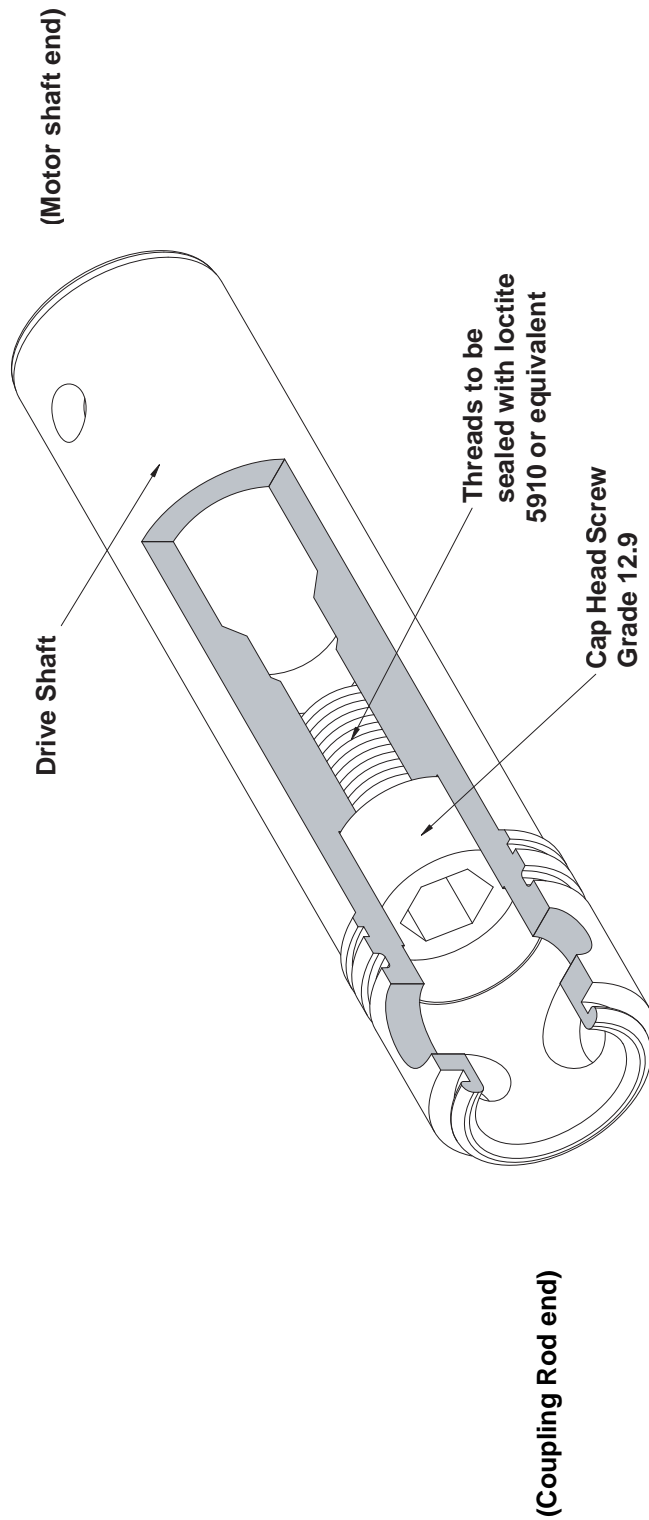

NOTE:
This screw may be removed to allow a jacking bolt to be used to aid removal of the drive shaft from the gearbox shaft.

NOTE: ENSURE THE CAP HEAD SCREW IS TIGHTEND & SEALED BEFORE ASSEMBLING WITH COUPLING ROD

Torque Tightening Figures

Pump Size	Body/Suct Chamber			Stator Tie Bars		Split Coupling Rod	Split Suction Chamber Halves
	Nm			Nm		Nm	Nm
	P526	P105	P530	P506	P503	P301	P540
Z14A		11			11	22	25
Z14K		11			11	22	25
Z14B		11			11	22	25
Z15A		11			11	22	35
Z15K		21			11	22	35
Z15B		21			11	43	35
Z16A		21			24	43	35
Z16K		21			24	43	35
Z16B		36			24	75	35
Z17A		36			24	75	45
Z17K		36			24	75	45
Z17B		36			24	75	45
Z18A		36			40	75	55
Z18K		36			40	75	55
Z18B	50	-	36		40	75	55
Z19A		90			75	75	70
Z19K		90			75	75	70
Z19B		90			75	75	70
Z1AA		90			75	75	70
Z1AK		90			75	75	70

Pin Joint Lubrication

PUMP MODEL	JOINT LUBRICATION CAPACITY (APPROX.) PER JOINT (ml)*	NON-FOOD APPLICATIONS ONLY		FOOD APPLICATIONS
		RECOMMENDED	SUITABLE ALTERNATIVE	
Z14A Z14B Z14K Z15A	22	KLUBER SYNTHESO D460 EP OIL	MOBILITH SHC 007 SEMI-FLUID GREASE	SHELL RETINAX CSZ
Z15B Z16A Z16K	45			
Z16B Z17A Z17B Z17K Z18A Z18K	55		MOBIL GEAR OIL SHC 320	
Z18B Z19A Z19B Z19K Z1AA Z1AK	95			

Recommended Lubrication & Service Intervals

COMPONENTS	ALL APPLICATION EXCEPT FOOD	FOOD APPLICATIONS ONLY	SERVICE COMMENTS
PUMP DRIVE JOINTS	SEE SECTION 5 PAGE 2		INSPECT AND LUBRICATE AS NECESSARY EVERY 4000 OPERATING HOURS
PUMP BEARINGS (WHERE FITTED)	BP Energrease LC2 OR EQUIVALENT		INSPECT AND RE-GREASE IF NECESSARY EVERY 12 MONTHS
GEARED DRIVERS (WHERE FITTED)	AS RECOMMENDED BY THE MANUFACTURER		
<p>NOTE: ABOVE SERVICE AND LUBRICATION INTERVALS ARE FOR GUIDANCE ONLY TO ENSURE MAXIMUM COMPONENT LIFE. PUMP WILL OPERATE FOR CONSIDERABLY LONGER PERIODS WITHOUT ATTENTION DEPENDING ON SERVICE CONDITIONS</p>			

UK and Europe

Mono Pumps Ltd, Martin Street, Audenshaw
Manchester, M34 5JA, England
T. +44 (0)161 339 9000
E. info@mono-pumps.com

Americas

NOV Monoflo, 9606 Kirkton
Houston, Texas 770495, USA
T. +1 281 200 1200
E. inquire@monoflo.com

Monoflo SA

Ing. Huergo 2239 - B1842GGW
Monte Grande
Buenos Aires
Argentina
T. +54 4296 8997
F. +54 4284 0323
E. inquire@monoflo.com

Australasia

Mono Pumps (Australia) Pty Ltd
Mono House, 338-348 Lower Dandenong Road
Mordialloc, Victoria 3195, Australia
T. +61 (0)3 9580 5211
E. ozsales@mono-pumps.com

Mono Pumps (New Zealand) Ltd
PO Box 71-021, Fremlin Place, Avondale
Auckland 7, New Zealand
T. +64 (0)9 829 0333
E. info@mono-pumps.co.nz

Asia

Mono Pumps Ltd, No. 500 YaGang Road
Lujia Village, Malu, Jiading District
Shanghai 201801, P.R. China
T. +86 (0)21 5915 7168
E. monoshanghai@nov.com

www.mono-pumps.com



One Company, Unlimited Solutions